

MARKETING MANAGEMENT	1079
CONSUMERS' ATTITUDES TOWARDS PURCHASING FASHION COUNTERFEITS	1080
Kostić - Stanković Milica, Cvijovic Jelena	
APPLICATION OF CROWDSOURCING IN MARKETING	1087
Vlastelica Bakic Tamara, Cicvaric Kostic Slavica, Nešković Ema	
METHODOLOGY FOR EXPLORING FACTORS THAT AFFECT PEOPLES INTENTION TOWARDS COSMETIC SURGERY	1092
Jovic Marija, Filipovic Vinka, Jovic Marko	
KEY ACCOUNT MANAGEMENT - STRATEGIC IMPERATIV IN POSTAL SERVICES	1098
Ožegović Spasenija, Šarac Dragana, Unterberger Marija	
ROLE OF MARKETING COMMUNICATION IN CANCER PREVENTION	1105
Cvijovic Jelena, Kostić - Stanković Milica, Krstic Goran	
VOJVODINA AS A TOURISM DESTINATION: CITIZENS' PERSPECTIVE	1113
Vranić Ivana, Cicvaric Kostic Slavica, Vlastelica Bakić Tamara	
THE EFFECTIVENESS OF MEDIA CAMPAIGNS IN COMMUNICATION WITH CHILDREN	1119
Malinović Anja, Vlastelica Bakic Tamara, Cicvaric Kostic Slavica	
CHALLENGES AND OPPORTUNITIES OF INTERNET MARKETING IN SERBIA AND THE WORLD	1126
Markov Jasmina, Stankov Biljana, Roganović Milijana	
THE EFFECTIVENESS OF ATL AND BTL ADVERTISING TECHNIQUES	1134
Šehović Marijana, Duduković Mirjana, Mladenović Jelena	

MARKETING MANAGEMENT

CONSUMERS' ATTITUDES TOWARDS PURCHASING FASHION COUNTERFEITS

Milica Kostić - Stanković¹, Jelena Cvijović²

¹ University of Belgrade, Faculty of Organizational Sciences, milicak@fon.rs

² University of Belgrade, Faculty of Organizational Sciences, jelenacvijovic85@gmail.com

Abstract: *The rapid growth of counterfeiting can be attributed to the increase in world trade, emerging of new markets, technology advancements and the increasing number of product categories that can be counterfeited. Copies of luxury fashion brands represent the most common category, as they incur low manufacturing costs and are easy to be sold due to growing consumer demand. Reason for the expansion of counterfeiting around the world is based on consumers' attitude that there is nothing unethical about buying or acquiring fakes. In order to suppress this activity, greater efforts should be put on creating consumers' awareness about multiple negative social and economic effects that counterfeiting actually have.*

Keywords: *fashion counterfeits, consumers, attitudes, motives, demand, negative effects*

1. INTRODUCTION

The phenomenon of counterfeiting, which is the general name for production, distribution and consumption of counterfeit goods, has significantly arisen during last two decades, expanding globally and affecting both developed and developing countries and, therefore has become a serious social and economic problem. Today, counterfeiting trade accounts more than 7% of the global trade and grows at the rate of 15% per annum (Ergn, 2010). Republic of Serbia, as developing country, represents one of the markets suitable for selling and buying such products, due to poor state of the economy and low purchasing power. China is the main producer of the counterfeit products in the world (Hung, 2003). Other sources of counterfeits are Russia, Argentina, Chile, Egypt, India, Israel, Lebanon, Thailand, Turkey, Ukraine, Venezuela, Brazil, Paraguay and Mexico (Chaudhry and Zimmerman, 2009).

Counterfeiting has been expanding due to strong worldwide and national demand (Amendolara, 2005). Therefore, greater interest has to be put on understanding consumer behaviour with regard to motivation for purchasing counterfeit goods. Legal consequences and consumer education are most effective options for addressing the demand side of the counterfeit issue (Norum and Cuno, 2011). Berman (2008) stated that companies that produce genuine brands should contribute to the reduction of the counterfeiting problem through the development of consumer education programs that emphasize the personal, social and economic dangers it causes.

Chaudry and Zimmerman (2009) noticed that the types of products being counterfeited are broadening (Figure 1). Although there is a huge number of product groups that can be copied, products with a high brand image and low production technology are the preferred targets of counterfeiters (Penz and Stöttinger, 2005). That's why branded or luxury fashion counterfeits represent the most common group of counterfeits (Pollinger, 2008). The OECD (2008) reported that fashion items (clothing, jewellery, accessories and footwear) represent the largest part of counterfeit trade, taking into account that textile sector and jewellery together make up 66,2% of all interventions by European Customs.

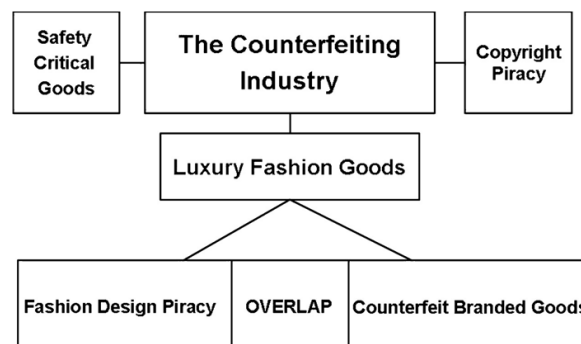

Figure 1. Mapping out counterfeiting (Wall and Large, 2010)

2. TYPES OF COUNTERFEITS

Generally, counterfeits are defined as reproduced copies that are identical or substantially indistinguishable to the legitimate articles, including packaging, trademarks and labelling (McCarthy, 2004). They attract consumers as they clearly look like the genuine brand, yet "cost only a fraction of the price of the original" (Rath et al., 2008). According to Yang and Fryxell (2009), counterfeiting represents the unlawful imitative manufacturing of products and services that are protected by owners' intellectual property rights with the goal to earn profit. The definition proposed by Staake et al. (2009) is following: "Counterfeit trade is the trade in goods that, be it due to their design, trademark, logo, or company name, bear without authorization a reference to a brand, a manufacturer, or any organization that warrants for the quality or standard conformity of the goods in such a way that the counterfeit merchandise could, potentially, be confused with goods that rightfully use this reference".

As suggested by Yang and Fryxell (2009), generally, there are two main kinds of counterfeits - the counterfeiting of commodities and the counterfeiting of symbols attached to products. One of earlier studies, made by Phau and Prendergast (1998), divided counterfeits into six categories. In case of first category, high-quality fakes, both stores and consumers can be misled, by confusing them with originals. Second category, called "piracy", considers that the customer is aware of the faked object which is usually sold at a significantly lower price. Third, imitations or "knock-offs" are not identical to the original, but they are similar in substance, name or form with a widely known product (Berman, 2008). Fourth category represent so called "grey products" that factories, contracted by the genuine brand manufacturers, produce in greater quantities than required and then sell as overruns illegally (Vida, 2007). Fifth category, custom-made copies or "super fake" products are replicas of trademark designs of branded products made by legitimate craftsmen and the only item missing from the original is the logo or brand name (Hilton et al., 2004). Goods that are similarly packaged or with similar trademarks and labelling are also considered counterfeits and represent the sixth group (Phau and Teah 2009).

Regarding the consumer's perspective, counterfeits can be either deceptive or non-deceptive. Deceptive counterfeiting involves purchases where consumers believe they have bought a genuine article when in fact it is a counterfeit (Staake et al., 2009), as is often the case in categories such as automotive parts, consumer electronics and pharmaceuticals (Vida, 2007). In other cases, however, consumers are typically aware that they are purchasing counterfeits, which is non-deceptive form of counterfeiting. It is particularly prevalent in fashion brands (Nia and Zaichkowsky, 2000) where consumers are "often able to distinguish counterfeits from genuine brands based on differences in price, the distribution channels, and the inferior quality of the product itself". Nevertheless, the quality of fashion copies has improved dramatically during recent years, even resulting in the existence of "super copies" (Wilcox et al., 2009). Gentry et al. (2006) also supported that the quality of counterfeit luxury products has improved over the years thus it is harder and harder to differentiate the counterfeits from the genuine luxury brands.

3. NEGATIVE EFFECTS OF COUNTERFEITING

Empirical and academic evidence show that counterfeiting is a harming and risky business (Lewis, 2009). It is more than evident that counterfeiting causes general negative influences on government tax revenues, market order and fair competition, as well as on overall economic development. Counterfeiters participate in the economic black market, because they pay no taxes, causing states to lose legitimate revenue (Ha and Lennon, 2006), so their damaging effect on businesses, national economies, consumers and on society as a whole is more than obvious. Consumers who purchase counterfeited articles risk funding nefarious activities, contributing to unemployment, creating budget deficits and compromising the future of their country in the global economy (UNICRI, 2009; Santos and Ribiero, 2006). The negative effects include loss of goodwill of brand names, lowering consumers' confidence in legitimate brands and company reputations which further lead to loss in sales or elimination from the market (Monirul and Han, 2012). Furthermore, there are increasing cases of health hazards and threats to consumer health and safety and severe economic anxiety for some developing countries that can be linked to counterfeiting (Gessler, 2009).

Gessler (2009) divides "the true costs of counterfeiting" - the consequences of the phenomenon, in six categories: the cost to brand owners, government burdens, the effects counterfeiting has on consumers, child and forced labour issues in the production of these counterfeits, organised crime and terrorist funding activities and the moral cost of counterfeiting. Some authors differentiate between two types of harm caused by the purchase of counterfeit goods: personal and societal harm. Personal harm means that the individual itself is affected by purchasing counterfeit products, while societal harm implicates that counterfeit trade affects the society as a whole. Thompson (2004) posit that "the average consumer does not consider overall societal issues when faced with the option of purchasing an original or a counterfeit product", which is the main reason for expansion of counterfeiting.

4. ATTITUDES TOWARD COUNTERFEIT FASHION PRODUCTS

In the case of explaining counterfeit purchase behaviour, Veloutsou and Bian (2008) and De Matos et al. (2007) suggest that the attitude towards buying fake products depends on the overall perceived risk, which is the most important variable to predict consumer attitude toward counterfeits. If it is moderate, it is highly likely that consumer will do the purchase. Bian and Moutinho (2009) found evidence that perceived risk is a factor that negatively influences the purchase intention of counterfeits. A person's overall perceived risk consists out of six different risk dimensions: financial, performance, psychological, physical, social and time risk (Veloutsou and Bian, 2008). Social risk can be defined as the negative outcome one attaches to "being caught by significant others" when possessing or purchasing a counterfeit. Time risk is seen as the time one might lose searching for a counterfeit article. Financial risk involves the potential loss of money when buying a counterfeit. Physical risk is the possibility of bodily harm or health hazard. Performance risk refers to the chance of malfunctioning of the fake product that is bought. In explaining psychological risk, the most appropriate definition is given by Penz et al. (2009): "psychological risk refers to the experience of anxiety or psychological discomfort arising from anticipated postbehavioral affective reactions such as worry and regret from purchasing and using the product".

As consumers obviously play a leading role in the maintaining of counterfeit trade (Yoo and Lee, 2009; Bian and Moutinho, 2008), it is important to gain a deeper insight in potential motives of consumer's willingness to purchase non-deceptive counterfeit products. Vida (2007) concluded that a consumers' attitude toward counterfeit luxury products refers to the degree people are able to rationalize counterfeiting practice with respect to the costs, pricing and quality of genuine with counterfeit products. The attitudes could be divided into two specific issues: attitudes towards counterfeiting and attitudes towards market practices. If a person's attitude towards counterfeiting is favourable, it is likely that he or she would consider the purchase of counterfeit products. The attitude towards market practices actually represents person's beliefs and feelings towards the operations of some organization. If a person holds an unfavourable attitude towards the high-profile operations of branded goods manufacturers and the snob appeal of their products, it is less likely that person would purchase the branded originals. Rather, these people are more likely to purchase the counterfeit version of branded goods (Wee et al., 1995).

The two major reasons why consumers develop positive attitudes toward buying counterfeits are economic benefits and hedonic benefits. The most obvious factor that motivates purchases of counterfeit brands is their relatively low price. In cases when consumers cannot afford to buy original fashion designer products because they are too expensive, but want to possess something that look alike, they are likely to decide on buying counterfeits. Consumers are not affected by low quality and poor materials because they do not see counterfeits as inferior choices when they experience such budget constraints. On the contrary, most of these consumers appreciate the economic benefits counterfeits provide them (Penz et al. 2009; Ang et al., 2001). Consumers believe they will have the identical appearance whether they wear or carry a counterfeit or an original brand, so they will get the prestige/status of the original brand without paying for it (Penz and Stottinger 2005). The hedonic benefits of counterfeit purchases impose that consumers buy counterfeit brands because they want to demonstrate that they can afford branded goods, to show that they belong to a particular social group, or to use the product for symbolic self-extension. They view that the brand names, labels, various design characteristics such as logo, colour etc. are valuable by themselves and they satisfy a desire for symbolic meanings such as social and financial status, recognition and superiority (Wee et al., 1995).

When it comes to the selection of fashion-related goods, some very specific factors determine buying behaviour. Determinants on intention to purchase counterfeit goods have been classified as psychographic (attitude toward counterfeiting, brand status and novelty seeking), demographic (age, educational attainment and income) and product-attribute (appearance, image, perceived fashion content, purpose and perceived quality) variables (Rath et al., 2008). Smith et al. (2008) found self-reported past buying behaviour as a strong predictor of future purchase intentions. Also Ouelette and Wood (1998) suggest that the frequency of performing certain behaviour in the past has a direct impact on future behaviour.

In literature, following factors are mentioned as major determinants of person's attitude towards counterfeiting and purchase intentions: fashion consciousness, public self-consciousness, ethical judgment and ethical obligation.

Fashion consciousness refers to a person's degree of involvement with the styles or fashion. An individual does not have to be either a fashion opinion leader or a fashion innovator to be considered fashion conscious. Fashion involvement represents a consumer's perceived importance of fashion clothing (O'Cass,

2001). Previous researches had demonstrated that fashion involvement influences consumer behaviour towards purchasing fashion products (Penz and Stottinger, 2005; Bertrandias and Goldsmith, 2006). Penz and Stottinger (2005) found that fashion involvement had a strong influence on an embarrassment potential and weakens the attitude that purchasing counterfeit products is a desirable behaviour. On the other hand, Wee et al. (1995) revealed that "for fashion related counterfeit products, purchase intention is determined by the similarities in appearance, quality and image projected by the counterfeit version compared to the originals", which means that those who are more fashion conscious are more likely to seek for "perfect counterfeits". Gentry et al. (2006) also found that consumers consider counterfeits as a relatively cheap way to keep up with the latest fashion trends.

It has been shown that consumers form positive attitudes toward things that help them define their social and personal identities, express who they are, who they want to be and how they want others to see them. Fashion-related goods may be seen as an especially effective product category in this regard (Dodd et al., 2000). Individuals who have a rather vague and uncertain self-concept tend to possess low self-esteem, which renders them less certain that they will be able to meet what they believe are others' standards for worthiness and make them more exposed to the outside influences on their self-concept. When people move on social scale, they may adopt new patterns of consumption to symbolize their new social position. Consumers who are buying branded products may be described as self-conscious and especially concerned about the impressions that they make (Penz and Stottinger, 2005). According to Roux and Korchia (2006), consumers who choose buying counterfeit over a genuine product are similarly concerned about impressions they leave on other people, although those projected images sometimes seem to create a tension or conflict between an original identity and a borrowed appearance.

The desire to possess various things can lead to a consumer acting unethically. "Consumer ethics can be defined as the moral rules, principles and standards guiding the behaviour of an individual (or group) in the selection, purchase, use or selling of a good or service" (Penz and Stottinger, 2005). The perception of an ethical issue is an important basis of the ethical decision-making process. A person who perceives an ethical problem tends to behave more ethically than an individual who does not. Ethical obligation represents an individual's internalized ethical rules, which reflect personal beliefs about appropriate behaviour (Shaw et al., 2000). According to Trevino (1992) ethical judgment is a cognitive process in which an individual judge which course of action is moral and form behavioural intentions based on that. In other words, if an action is judged as ethical, one is more likely to form an intention to perform it. Oppositely, if an action is judged as unethical, one is less likely to form an intention to engage in the action (Nguyen and Biderman, 2008). According to Penz and Stottinger (2005) the ethical perception plays an important role in the consumption behaviours, as it may have a self-binding effect on the individual. Consumers who have a higher ethical disposition would be more embarrassed if they were discovered wearing counterfeits and, therefore, most often choose not to buy such products.

5. STRATEGIES TO FIGHT COUNTERFEITING ACTIVITIES

Although governments and manufacturers of genuine brands, who experience both economic and noneconomic losses, take some action to protect their products from being copied, it is difficult to protect intellectual property rights in many countries, especially in less developed countries like Serbia, due to weak legal structure, their implementation and corruption. Law enforcement strategies, based on legal issues and concerns, in the form of more stringent penalties for convicted counterfeiters should be implemented by states authorities. Some manufacturers introduce product and packaging changes in the form of magnetic codes and special inks, holograms and implanting high technology "fingerprints" on parts of the articles as a symbol for authenticity (Figure 2). Retailers are most commonly blamed for the proliferation of counterfeits (Prendergast et al. 2002), as they perceive the selling of counterfeits as risk and cost free and those counterfeiters rarely go out of business (Green and Smith, 2002). Olsen and Granzin (1992) stated that retailers would accept the responsibility in fighting counterfeits only if the government and manufacturers share the obligation. If they feel that it is a trivial problem, they will neither share the responsibilities nor support the manufacturers and the governmental authorities.

But, law enforcement targeted at counterfeit manufacturers and retailers may not solve the entire problem, as its root derives from the consumers' willingness to purchase copied products. Manufacturers of original brands, together with the countries' policy makers, should more intensively expand public awareness of the harm of counterfeiting through advertising, public forums etc. Marketing campaigns designed to evoke public awareness of counterfeiting may have a positive echo and change the attitude towards buying such products. Especially successful can be integrated marketing communications campaign that has a goal to directly influence the behaviour of a heterogeneous target public (Kostic – Stankovic, 2011). Synergy of various communication channels should be used for informing the consumers about the societal

consequences of counterfeiting, in order to lower purchase intentions of counterfeit products. Penz et al. (2009) found that "informing consumers about the business practices of counterfeiters may change their attitudes toward the phenomenon". Thus, it is needed to change consumers' attitude in order to reduce demand for such counterfeit luxury products and reverse this growing trend.

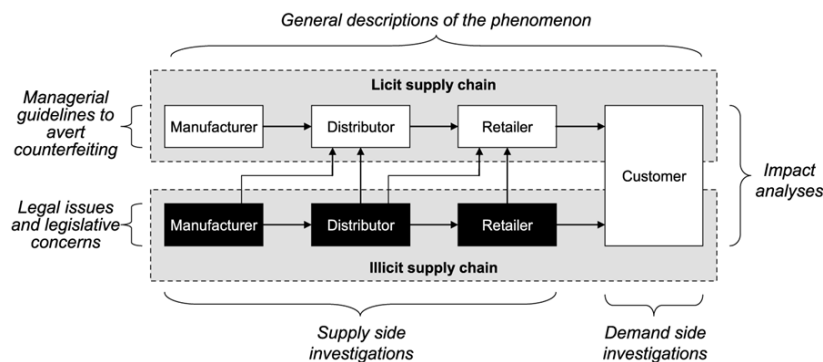

Figure 2. Strategies to suppress counterfeiting (Staake et al., 2009)

6. CONCLUSION

Despite the general favourable attitude of those consumers who believe that fashion counterfeits bring benefits such as cheaper price and luxurious image, negative effects of purchasing copied products are nowadays more than obvious and serious. Therefore, it is necessary to change consumers' attitude in order to reduce demand for counterfeit fashion products and. Besides imposture of legal restrictions, it is important to create public awareness that purchasing fashion counterfeits is unethical activity that holds certain risks, such as poor quality, loss of time and money, potential social embarrassment, as well as participation in the economic black market.

REFERENCES

- Amendolara, L. (2005). Knocking out knock-offs: effecting the criminalization of trafficking in counterfeit goods. *Fordham Intellectual Property, Media and Entertainment Law Journal*, 15, 789-836.
- Ang, S.H., Cheng, P.S., Lim, E.A.C., & Tambyah, S.K. (2001). Spot the difference: Consumer response towards counterfeits. *Journal of Consumer Marketing*, 18(3), 219-235.
- Berman, B. (2008). Strategies to Detect and Reduce Counterfeiting Activity. *Business Horizons*, 51, 191-199.
- Bertrandias, L., & Goldsmith, E. (2006). Some psychological motivation for fashion opinion leadership and fashion opinion seeking. *Journal of Fashion Marketing Management*, 10(1), 25-40.
- Bian X., & Moutinho, L. (2009). An investigation of determinants of counterfeit purchase consideration. *Journal of Business Research*, 62, 368-378.
- Chaudhry, P.E., & Zimmerman, A. (2009). *The Economic of Counterfeit Trade*. Berlin: Springer – Verlag.
- Dodd, C.A., I. Clarke, S. Barson, & Houston, V. 2000. Looking the part: Identity, meaning and culture in clothing purchasing-theoretical considerations. *J. Fashion Market. Manage.*, 4(1): 41-48.
- Ergn, E.A. (2010). The rise in the sales of counterfeit brands: The case of Turkish consumers. *African Journal of Business Management*, 4(10), 2181-2186.
- Gentry, J. W., Putrevu, S., & Shultz II, C. J. (2006). The Effects of Counterfeiting on Consumer Search. *Journal of Consumer Behavior*, 5(3), 245-256.
- Gessler, C. (2009). *Counterfeiting in The Luxury Industry: The True Costs of Counterfeit Goods*, Germany: VDM Verlag.
- Green, R.T., & Smith, T. (2002). Executive Insights: Countering Brand Counterfeiters. *Journal of International Marketing*, 10 (4), 89-106.
- Ha, S., & Lennon, S. (2006). Fashion intent for fashion counterfeit products: Ethical ideologies, ethical judgments and perceived risks. *Clothing and Textile Research Journal*, 24(4), 297-315.
- Hilton, B., Chong J. C., & Chen, S. (2004), The Ethics of Counterfeiting in the Fashion Industry: Quality, Credence and Profit Issues, *Journal of Business Ethics*, 55 (4), 345-354.
- Hung, C.L. (2003). The business of product counterfeiting in China and the post WTO membership environment. *Asia Pacific Business Review*, 10(1), 58-77.
- Kostic – Stankovic, M. (2011). *Integrated Business Communications*. Belgrade: Faculty of Organizational Sciences.

- Lewis, K. (2009). The Fake and the Fatal: The Consequences of Counterfeits. *The Park Place Economist*, 17 (1), 47-58.
- McCarthy, J.T. (2004). *McCarthy's Desk Encyclopedia of Intellectual Property*, Third Edition. Washington, DC: Bureau of National Affairs.
- Monirul, I., & Han, H. J. (2012). *International Journal of Physical and Social Sciences Cross Cultural Counterfeit Characteristics and Anti-counterfeit Strategy*, 2 (7), 341-359.
- Nguyen, N.T., & Biderman, M.D. (2008). Studying ethical judgments and behavioural intentions using structural equations: Evidence from the multidimensional ethics scale. *Journal of Business Ethics*, 83, 627-640.
- Nia, A., & Zaichkowsky, J.L. (2000). Do Counterfeits Devalue the Ownership of Luxury Brands? *Journal of Product and Brand Management*, 9 (7), 485-49.
- Norum, P., & Cuno, A. (2011). Analysis of the demand for counterfeit goods. *Journal of Fashion Marketing and Management*, Emerald Group Publishing, 15 (1), 27-40.
- O'Cass, A. (2001). Consumer self-monitoring, materialism and involvement in fashion clothing. *Australian Marketing Journal*, 9 (1), 46-60.
- OECD (2008). *The Economic Impact of Counterfeiting and Piracy Organisation for Economic Co-operation and Development*. Paris: The Economic Impact of Counterfeiting and Piracy.
- Olsen, J.E., & Granzin, K.L. (1992). Gaining retailers' assistance in fighting counterfeiting: Conceptualisation and empirical test of a helping model, *Journal of Retailing*, 68 (1).
- Ouelette, J. A., & Wood, W. (1998). Habit and Intention in Everyday Life: The Multiple processes by Which Past Behavior Predicts Future Behavior. *Psychological Bulletin*, 124 (1), 54-74.
- Penz, E., & Stöttinger, B. (2005). Forget the "real" thing, take the copy! An explanatory model for the volitional purchase of counterfeit products. *Advances in Consumer Research*, 32(1), 568-575.
- Penz, E., Schlegelmilch, B.B., & Stöttinger, B. (2009). Voluntary Purchase of Counterfeit Products: Empirical Evidence From Four Countries. *Journal of International Consumer Marketing*, 21 (1), 67-84.
- Phau, I., & Prendergast, G. (1998). Counterfeit Products - Riding the Waves in the New millennium. *Business and Economics Society International Conference*, Rome, 1, 45-55.
- Phau, I., & Teah, M. (2009). Devil Wears (counterfeit) Prada: A study of Antecedents and Outcomes of Attitudes Towards Counterfeits of Luxury Brands, *Journal of Consumer Marketing*, 26 (1), 15-27.
- Prendergast, G., Chuen, L. H., & Phau, I. (2002). Understanding Consumer Demand for Non-deceptive Pirated Brands. *Marketing and Intelligence Planning*, 20 (7), 405-416.
- Pollinger, Z. A. (2008). Counterfeit Goods and Their Potential Financing of International Terrorism. *The Michigan Journal of Business*, 1 (1), 85-102.
- Rath, P.M., Bay, S., Petrizzi, R., & Gill, P. (2008). *The Why of the Buy: Consumer Behaviour and Fashion Marketing*. New York: Fairchild.
- Roux, D., & Korchia, M. (2006). Am I what I wear? An exploratory study of symbolic meaning associated with secondhand clothing. *Advanced Consumer Research*, 33(1), 29-35.
- Santos, J.F., & Ribiero, J.C. (2006). An exploratory Study of The Relationship Between Counterfeiting and Culture. *Polytechnical Studies Review*, 3 (5/6), 227-243.
- Shaw, D., Shiu, E., & Clark, I. (2000). The contribution of ethical obligation and self-identity to the theory of planned behavior: An exploration of ethical consumers. *Journal of Marketing Management*, 16 (8), 879-894.
- Smith, J. R., Terry, D.J., Manstead, A.S.R., Louis, W.R., Kottermanand, D., & Wolfs, J. (2008). The Attitude-Behavior Relationship in Consumer Conduct: The Role of Norms, Past Behavior and Self-Identity. *The Journal of Social Psychology*, 148 (3), 311-333.
- Staake, T., Thiesse, F., & Fleisch, E. (2009). The Emergence of Counterfeit Trade: A Literature Review. *European Journal Of Marketing*, 43 (3/4), 320-349.
- Thompson, N. (2004). *Bootleg Billion. The Impact of the Counterfeit Goods Trade on New York City*. New York: Office of the Comptroller.
- Trevino, L.K. (1992). Moral reasoning and business ethics: Implications for research, education and management. *Journal of Business Ethics*, 11, 445-459.
- UNICRI (2009). Counterfeiting: A Global Spread, A Global Threat, *Trends. Organized Crime*, 12, 59-77.
- Veloutsou, C., & Bian, X. (2008). A Cross-national Examination of Consumer Perceived Risk in The Context of Non-deceptive Counterfeit Brands. *Journal of Consumer Behaviour*, 7 (1), 3-20.
- Vida, I. (2007). Determinants of Consumer Willingness to Purchase Non-Deceptive Counterfeit Products. *Managing Global Transitions*, 5 (3), 253-270.
- Wall, D.S., & Large, J. (2010). Jailhouse Frocks: Locating the Public Interest in Policing Counterfeit Luxury Fashion Goods, *British Journal of Criminology*, 50 (6), 115 - 128.
- Wee, C. H., Tan S.J., & Cheek. K. H. (1995). Non-Price Determinants of Intention to Purchase Counterfeit Goods - an exploratory study. *International Marketing Review*, 12 (6), 1-20.
- Wilcox, K., Kim, K. M., & Sem, S. (2009). Why Do Consumers Buy Counterfeit Luxury Brands? *Journal of Marketing Research*, 46 (2), 247-259.

- Yang, D., & Fryxell, G.E. (2009). Brand positioning and Anti-counterfeiting Effectiveness: A study of Managers, Perceptions of Foreign Brands in China. *Management International Review*, 49, 759-779.
- Yoo, B., & Seung-Hee, L. (2009). Buy Genuine Luxury Fashion Products or Counterfeits? *Advances in Consumer Research*, 36, 280-286.

APPLICATION OF CROWDSOURCING IN MARKETING

Tamara Vlastelica Bakić¹, Slavica Cicvarić Kostić², Ema Nešković³

¹Faculty of Organizational Sciences, tamarav@fonrs

²Faculty of Organizational Sciences, cicvarics@fon.rs

³Faculty of Organizational Sciences, ema.neskovic@fon.bg.ac.rs

Abstract: *Nowadays, a growing number of companies is focusing on cost optimisation and lowering labour expenses. In this climate, companies are turning to talented and educated individuals who are ready to participate in their projects. Whether it is for profit or non-profit purposes, or it is done by using online technologies or without them, this new business model is called crowdsourcing. This term is used for describing outsourcing process that focuses on the power of people for solving different types of tasks. The aim of this paper is to define crowdsourcing and its difference from similar models such as open innovation, user innovation, open source and outsourcing. The authors put focus on the application of crowdsourcing in marketing, particularly in market research, product development and promotion, as well as on examples of successful practice in these areas. Finally, the conclusions regarding further use of this model will be presented by taking a closer look at its advantages and limitations.*

Keywords: *crowdsourcing, business model, marketing, market research, product development, promotion*

1. INTRODUCTION

The introduction of Web 2.0, opposite to the traditional Internet has marked the beginning of new business era that companies are currently adapting to. Le Deuff (2007) and O'Reilly (2005) describe Web 2.0 as "the utilisation dimension and not to the physical network that supports it", which tends to encourage sharing between users and collaboration that opens many new options for everyday business. By using Web 2.0, a company can switch from outsourcing activities to other countries or firms specialised in certain field to engaging individuals in its everyday activities (Nešković et. al., 2012). This model enables companies to gather ideas and suggestions regardless of the person's location. Crowdsourcing is one model of using people's ideas for improving everyday business, as well as gathering ideas for future projects of the company.

The concept of crowdsourcing has been present for a while, but the first use of the term was in an article published in Wired magazine in 2006 and written by Jeff Howe and Marc Robinson. Since 2006 the word "crowdsourcing" has been mentioned many times in the growing Internet community, in magazines and books. The term "crowdsourcing" has been discussed by Dahlander and Magnusson, (2008), and Agerfalk and Fitzgerald, (2008) and it has only been mentioned as an example of Web 2.0 by Tapscott and William (2007) and Albors et al. (2008). "The power of the crowd" (Howe, 2006) is related to many different versions of the contribution that a crowd makes, as well as different areas of use. Therefore, it is very important to distinguish crowdsourcing from similar models of using the contribution of a crowd. Most commonly, the terms mistaken for crowdsourcing are open innovation, user innovation, open source and outsourcing.

Open innovation and user innovation start from the same point as crowdsourcing – in the world of distributed knowledge, companies should not rely on their own research and development, but they should decide to gather some of their ideas and R&D functions from other companies and individuals. Open innovation is related to cooperation between firms, and user innovation is focusing on cooperation between product users who are solving issues with final products. Both open and user innovation are focusing on innovations and originality, while crowdsourcing is not restricted to innovations and often provides solutions that are not innovative at all. Open source can be explained as the application of crowdsourcing in IT industry. Howe (2008) describes crowdsourcing source as "an application of the open source principles to other industries". Brabham (2008) adds to that by saying that "it is obvious that crowdsourcing is not restricted to software development". While it is obvious that there are undisputable similarities in the business model of open source and crowdsourcing, crowdsourcing is a wider area and has a wider application than solely IT industry. The basic process of crowdsourcing and outsourcing is the same, with a client company that is seeking help from another subject. The basic difference between these two is that outsourcing is mainly focused on getting support and help from institutions, while crowdsourcing focuses on getting ideas from individuals.

2. DEFINITION OF CROWDSOURCING

Crowdsourcing is composed of two words: crowd and outsourcing and basically it means outsourcing to the crowd. It was first used on an Internet forum, but it was widely popularised by Howe and Robinson after they published an article in Wired magazine. Howe (2008) gives definition of crowdsourcing: “Simply defined, crowdsourcing represents the act of a company or institution taking a function once performed by employees and outsourcing it to an undefined (and generally large) network of people in the form of an open call.” He adds that “the crucial prerequisite is the use of the open call format and the wide network of potential labourers”. In a book he recently published and in posts on his blog (2008 and 2009), Howe gives two more precise definitions of crowdsourcing – *The White Paper Version*, and *The Soundbyte Version*. In *The White Paper Version* he describes crowdsourcing as “the act of taking a job traditionally performed by a designated agent (usually an employee) and outsourcing it to an undefined, generally large group of people in the form of an open call”, while *The Soundbyte Version* describes crowdsourcing as “the application of Open Source principles to fields outside of software”.

This is the basic process of crowdsourcing: First of all, a company identifies processes and activities that need to be improved by outsourcing them. Instead of turning to another company for help, or trying to complete these actions within a company, they are “released to a crowd of outsiders who are invited to perform the task on the firm’s behalf for a stipulated fee” (Whitla, 2009). It can be done in two ways: by limiting the crowd to a group of people with qualifications of previous experience in the area, or by issuing an open call to all interested parties. These two options can be combined by limiting the call to the people from the area of expertise or to people who are most likely to have skills for successfully completing the task. Whitla (2009) notices that “sometimes a single task can be completed by many different users and each can be paid if they successfully complete the task”. This sentence sums up the idea of crowdsourcing – enabling talented individuals to get paid for the jobs they do in their own dynamic and by using available resources. It also explains why crowdsourcing is becoming widely used: companies are able to get the solutions they need by paying less and being able to choose who they are hiring for the job.

Whitla (2009) describes the crowdsourcing process by using an example of Amazon’s Mechanical Turk. Amazon’s Turk was named after Hungarian nobleman Wolfgang von Kempelen who invented “the Turk” - the first machine capable of beating human at a chess game. Mechanical Turk is a platform that provides simple tasks - HIT’s (human intelligence tasks) to individuals. These tasks require very little time and effort to complete, but they cannot be done by computers. Therefore, individuals are solving them and getting paid from couple of cents up to a US dollar, depending on their effort. Whitla (2009) uses HIT’s to describe the process of crowdsourcing.

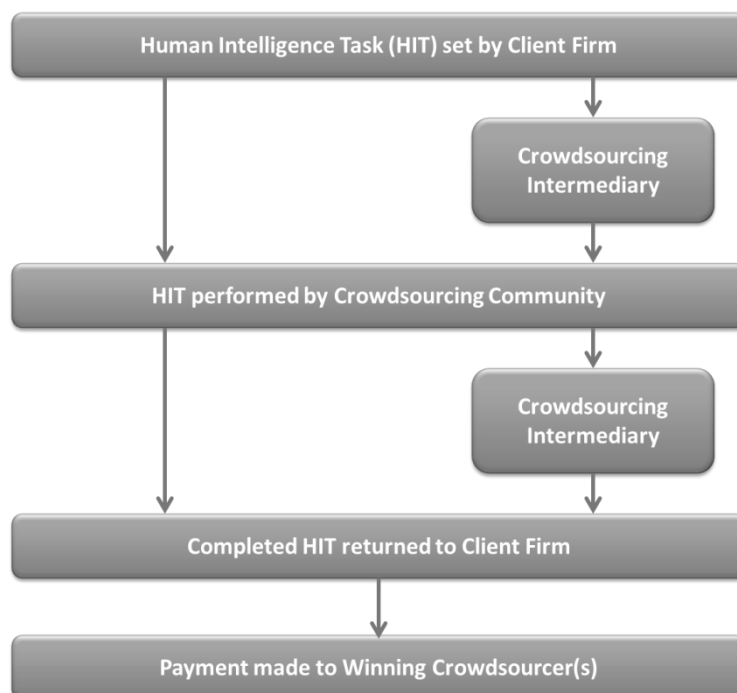

Figure 1: Crowdsourcing process

The basic model of crowdsourcing is the same and it is shown in Figure 1. There are alterations to this model depending on the industry and the type of tasks, but the idea of paying the crowd to complete certain processes remains as previously explained.

3. APPLICATION OF CROWDSOURCING

A call for crowdsourcing can be published in form of an open call or it can be limited to a certain number of people, as was previously mentioned. The question that arises is: What types of tasks can be crowdsourced? There are three types of tasks that can be outsourced to a crowd: routine tasks, complex tasks and creative tasks (Schenk and Guittard (2009)).

Routine tasks are a type of tasks that can be done very quickly and easily while requiring minimum time, such as data collection or marking text and images. This type of effort is usually awarded by micropayments. A perfect example of this routine are ReCaptcha, Open Street Map (OSM) and TxtEagle. ReCaptcha is widely used by websites for text recognition, when it is necessary to distinguish virtual robots from humans. OSM is used for collecting geographical data for creating a world map. Finally, TxtEagle helps mobile phone users to complete tasks by sending a text message. Routine tasks are, in most cases, published as an open call, given that almost anyone can participate in solving them.

Complex tasks that require more skills and knowledge are often limited to a closed group of people. This type of tasks can be solved in both profit and non-profit sector, and the companies pay more due to the effort required to complete the task successfully.

Finally, the third group of tasks are creative tasks. This is the earliest type of crowdsourcing which started long before the Internet, in the form of designer contests and competitions.

Companies usually crowdsource creative tasks with limitations only in the form of the solution that is required. This way the original and creative solutions are provided to the company. Monetary compensation for these tasks depends on the type of task, but usually these tasks are paid the most, varying from couple of hundred to couple of thousand US dollars.

4. APPLICATION OF CROWDSOURCING IN MARKETING ACTIVITIES

Even though there are many areas where crowdsourcing can be used, this paper will focus on the application of crowdsourcing in marketing. The main reason to do so is due to the fact that a growing number of firms is turning to customers and focusing on their requirements and preferences. The best way to do it is by turning to crowds for inspiration and ideas by using crowdsourcing.

According to Dawson (2011), there are several ways of applying crowdsourcing in marketing. These are shown in Table 1.

Table 1. Marketing application of crowdsourcing

Application	Description
Content creation	Generating marketing content such as videos, images or copy.
Idea generation	Creating ideas to identify or develop marketing initiatives.
Product development	Identifying insights to enhance existing products or develop new ones.
Customer insights	Gathering customer perspectives on current or potential products or marketing initiatives.
Customer engagement	Building greater participation and affiliation with the brand and company.
Customer advocacy	Tapping customers to spread word to their personal networks about products or services.
Pricing	Gaining insights on attitudes to possible pricing strategies.

Content creation is widely crowdsourced by giving customers a chance to provide content in different forms. Idea generation has been one of the most useful applications of crowdsourcing, given that there is a number of companies that benefited from having creative ideas coming from the crowd. One of the best examples is Starbucks's portal My Starbucks Idea, which has generated over 100.000 ideas for different aspects of business. Some of these ideas are related to the third area of application – product development. Dell's IdeaStorm portal is another great example of company benefiting from its loyal and creative customers, as

well as people with good ideas for new products. Customer insight, engagement and advocacy are a type of crowdsourcing primarily focusing on a narrow crowd – the customers, given that it is required to be a user of a product/service to be able to contribute in these areas. Finally, the question of pricing is often resolved by asking the people how much are they willing to pay for a certain product or a service.

Whitla (2009) was researching Human Intelligence Tasks (HIT's) and he identified the fields of marketing that are most suitable for their use, taking into consideration the nature of the tasks. By reviewing literature and already published HIT's, he singles out marketing research, product development and advertising and promotion as areas of marketing where crowdsourcing is most successfully used.

4.1. Use of crowdsourcing in market research

The most common form of applying crowdsourcing in market research is collecting data through surveys and questionnaires. Respondents are given a number of simple questions and the results are later used for creating product strategy. Given that these surveys provide monetary compensation to respondents, there is one big problem when using crowdsourcing for research: providing false data. Whitla (2009) notices that firms may restrict online surveys to a targeted population and that there is no way to prevent someone from imitating demographic to earn extra money. The payment may affect responses in another way – by keeping in mind that the company is paying them, many respondents may provide responses that represent an unrealistic image of a company or so called “desired responses”. The best way to prevent this from happening is by using complex questionnaires that require some fields to be filled in own words, as well as requiring a minimum number of words. Poynter (2013) argues that, in recent years, many companies are researching the market by placing projects on crowdfunding sites to see if people are willing to back it with their money. The clear distinction between people's opinions and their will to pay for something can be noticed, which is a very useful pointer for future success of the project. A popular example of using crowdsourcing in market research is Springwise, a company that keeps a network of over 8.000 professionals who contact the firm when they discover an interesting product, service or a business model. The company later sells the trend predictions to interested parties. Kaggle.com is another popular example, as the website gathers information from the crowds and does predictive analysis based on it.

4.2. Use of crowdsourcing in product development

Product development based on crowdsourced ideas is a constantly growing branch. Even though open innovation is most commonly used in product development, as companies are looking for innovative solutions to their issues, crowdsourcing is widely used as well. Von Hippel (1998, 2006) states that firms have been using consumer inputs for a long time and that manufacturers have been collecting inputs for developing new products for years. In crowdsourcing for product development there are three key differences to open innovation. Firstly, it is not limited only to customers, but includes potential customers or anyone willing to assist and provide their ideas. Secondly, it enables companies to get direct feedback, without the third party (such as distributors) involved in the process. Finally, companies can select specific areas where the improvements should be made and limit enquires to these areas. There are numerous examples of applying crowdsourcing in product development, including a crowdsourcing company InnoCentive, specialised in offering solutions to R&D problems to companies. Their clients include Proctor and Gamble, Boeing, DuPont, and they offer up to 100.000 US dollars as a winning prize for best solutions.

4.3. Use of crowdsourcing in advertising and promotion

Third most common use of crowdsourcing is in advertising and promotional activities. This model of crowdsourcing has become very popular in the past couple of years, given that its main advantage is enabling companies to save a lot of money and use the crowd to spread their message. The companies with bigger advertising budgets have been collaborating with the crowds for a while by including them in projects in the form of an open call, or even by paying them to post positive comments on blogs and websites. In a recent article, Kirby (2013) mentions six new modes of advertising for the future, and crowdsourcing is one of them. Her article focuses on a successful example of Oreo's campaign “Daily Twist”. The campaign was based on launching a 100-day series of cookies inspired by the news nominated by the crowd. The campaign resulted in 4.400% rise in sharing Oreo's Facebook page in just three months, with a significant rise in sales.

Crowdsourcing can be used in promoting or re-building brand identity of an institution, or even a location, as was the case with Connecticut (Birkner, 2013). With limited marketing budget and expensive media markets in targeted areas (especially Boston and New York City), the Office of Tourism switched to a creative approach by inviting locals to take part in a campaign “What's Your Connecticut Story?” in February 2012. The campaign focused on getting personal experiences from Connecticut and promoting them on a website

and a Facebook page. Following a success of this campaign, a new campaign “Still Revolutionary” was launched in May 2012. These two campaigns generated a total of 1.1 billion media impressions, 140.000 Facebook fans and 18% increase in awareness of Connecticut as a place to visit among neighbouring states. The successful campaign tends to become a tradition, given that another Fan Favourite campaign was launched in April 2013.

5. CONCLUSION

This paper presented many areas where crowdsourcing can be applied, even though it is a business model that is still in its developing stages. The increase of competition and limited budgets are some of the drivers that will help crowdsourcing become widely applied and popular model in the future. The authors presented successful examples of application of crowdsourcing in marketing; however, there are downsides to this model as well, and in the future the improvements must be taken into consideration.

First and the biggest problem arises from the sample – even though it is common to believe that more people guarantee better results, it may not be the case, especially when applying crowdsourcing in market research. This can prevent relevant information from getting to the companies. That is why it is important to work on improving mechanisms for filtering information and choosing participants. There are issues and limitations regarding the areas of expertise and qualifications required to successfully participate in crowdsourcing. Further research should focus on participants and better segmentation and profiling, so that results they provide can be improved.

Further use of crowdsourcing in marketing is heading towards social media and the use of social networks, as the source of the crowd, as well as the channel for placing a message and implementing marketing activities.

REFERENCES

- Agerfalk, P, Fitzgerald, B. (2008), Outsourcing to an unknown workforce: exploring open sourcing as a global sourcing, *MIS Quarterly*, 32(2), (p. 385-409)
- Albors, J, Ramos, J.C, Hervás. J.L. (2008), New learning network paradigms: Communities of objectives, crowdsourcing, wikis and open source, *International Journal of Information Management*, (p. 194-202)
- Birkner, C. (2013), A “Revolutionary” Rebrand, *Marketing News*, May 2013, (p. 8-10)
- Brabham, D. (2008), Crowdsourcing as a model for problem solving: An Introduction and Cases, *Convergence, The International Journal of Research into New Media Technologies*, 14(1), (p. 75-90)
- Dahlander, L, Magnusson, M. (2008), How do firms make use of open source communities?, *Long Range Planning*, 41, (p. 629-649)
- Dawson, R. (2011), *Getting Results From Crowds: The definitive guide to using crowdsourcing to grow your business*, Advanced Human Technologies Inc, ISBN-13: 978-0984783809
- Hempel, J. (2007, January 18), Tapping the wisdom of the crowd, *Business Week*, retrieved from http://www.businessweek.com/innovate/content/jan2007/id20070118_768179.htm
- Howe, J. (2006), The rise of crowdsourcing, *Wired*, 14(6)
- Howe, J. (2008), *Crowdsourcing*, Crown Publishing Group, New York
- Kirby, J. (2013), Creative That Cracks the Code, *Harvard Business Review*, March 2013
- Neskovic, E, Pavicevic, S, Dacic, J (2012), Crowdsourcing as a platform for innovative business and marketing approaches, *Symorg 2012 proceedings*, ISBN 978-86-7680-255-5, (p. 1150-1155)
- Poynter, R. (2013), Crowdsourcing lessons for market research, retrieved from <http://www.research-live.com/opinion/crowdsourcing-lessons-for-market-research/4009537.article>
- Schenk, E, Guittard, C. (2009, December), Crowdsourcing: What can be Outsourced to the Crowd, and Why?, *halshs-00439256*, version 1-8
- Tapscott, D, William, A.D. (2007), *Wikinomics*, Pearson Education
- Vivacqua A.S., Borges M.R.S., (2012) Taking advantage of collective knowledge in emergency response systems, *Jurnal of Network and Computer Applications*, 35, (p. 189-198)
- Von Hippel, E. (1998), *The Sources of Innovation*, London and New York: Oxford University Press
- Von Hippel, E. (2006), *Democratising innovation*, Cambridge, MA: MIT Press
- Whitla, P. (2009), Crowdsourcing and its application in marketing activities, *Contemporary Management Research*, Vol. 5, No. 1, (p. 15-28)

METHODOLOGY FOR EXPLORING FACTORS THAT AFFECT PEOPLES INTENTION TOWARDS COSMETIC SURGERY

Marija Jovic¹, Vinka Filipovic,³ Marko Jovic²

^{1,2} University of Belgrade, Faculty of Organizational Sciences, marijaj@fon.rs

³Clinic for Burns, Plastic and Reconstructive Surgery, Clinical Center of Serbia, markojovic01@yahoo.com

Abstract: *In this work authors developed methodology for exploring factors that contributes to peoples intention towards cosmetic surgery. From the available literature, one could not find the method to follow throughout process of analysing different factors that could contribute to formation of intention to undergo cosmetic intervention. Authors have proposed that methodology presented in this work could significantly contribute to revealing and understanding these factors. Methodology was developed applying the Theory of Planned Behaviour which provides good basis for empirical research on attitudes, subjective norms, and perceived behavioural control that together influence peoples' intention. Proposed methodology is applied on domestic – Serbian market, and the results are shown in further text. According to the results of conducted statistical analyses, authors created three scales for measuring intention of patients to undergo cosmetic surgery, namely attitudes toward cosmetic surgery, subjective norms, and perceived behavioural control, as main constructs of intention towards undergoing cosmetic surgery. Methodology presented in this work provides an excellent guide throughout the process of revealing and understanding factors that affects intention towards cosmetic surgery. At the same time, this methodology can be applied in different fields of contemporary business issues in the process of understanding behaviour of a modern customer.*

Keywords: *Methodology, Theory of Planed Behaviour, intention towards cosmetic surgery, attitude towards cosmetic surgery, subjective norms, perceived behavioral control.*

1. INTRODUCTION

In society, where celebrities are presented as extremely good looking, where information technologies and new ways of doing business are dominating, peoples look at each other more critically, and aesthetic improvements of the body are more and more fashionable. In such a society, cosmetic surgery is another one of alternatives in choices during life, besides fashion, recreation, and different kinds of therapy (Elliott, 2008).

There are opinions that the increase in cosmetic surgical procedures leading to a dangerous direction and fulfilment of themselves should be closely linked with a perfect physical appearance, but it can be acquired through spirituality, art, nature, love, learning and other activities (Lusted, 2010). On the opposite side are opinions that the existence of cosmetic surgery has many positive aspects. Correcting birth defects, burns, wounds, physical characteristics help the man to restore confidence and the ability to patients to feel more attractive and confident (Lusted, 2010).

In the past, people who were born with defects such as cleft lip, cleft palate and other deformities, were forced to live with it. These people were sentenced to others lifelong staring at them, to hide them or, in some cases, to be held in the circus. Cosmetic and reconstructive surgery can improve many of these birth defects, thus the children spared from teasing, and then have more confidence. The benefits of cosmetic surgery also have people with minor deformities, such as droopy ears, which can be corrected, or large and ugly marks, that may be utilized.

Aesthetic procedures depend on the age, gender and ethnicity of the patient. Women usually opt for interventions that will rejuvenate them and made them more attractive. Among women, the most common cosmetic procedures are breast enlargement, liposuction, eyelid surgery, abdominoplasty (removal of excess skin from the abdomen), and breast reduction. Men undergoing procedures that will make them younger and more handsome with them is the most common hair transplantation, liposuction, eyelid surgery, nose surgery and breast reduction. Among teenagers, the most common operations are corrections of the deficiencies, which others laugh at, and the most common operation is nose reshaping (Lusted, 2010). Belonging to a certain ethnic and cultural environments can also have an impact on whether someone will have cosmetic surgery. Some people will undergo surgery to make them look less ethnic, for example. Asian women are

doing the surgery of the eyelids to make their eyes were round and large, some American Jews and African-Americans are changing shape of the nose to make it smaller and more rounded and more like the nose of the Western nations.

Many of researches shows that, in temporary culture and society, people that looks younger and more pleasant, progress faster at work and earn more money than their colleagues who are less attractive and look older (Rinzler, 2009). Beautiful people are seen more positively than others (Lorenzo et al. 2010). Cosmetic surgery produces psychological effects that could be quantified by quality of life, self-confidence, satisfaction with personal appearance, less weight dissatisfaction, and increased psychological well-being (Rankin et al. 1998). To the extent that people are exposed to messages about the importance of attractiveness, they should be more concerned with their own appearance and, perhaps, more open to using the various means through which cultural standards can be achieved.

Despite the expectations of some authors that cosmetic intervention are becoming a common practice in achieving the cultural norms of appearance and the way to restore or gain beauty, youth, sex-appeal, reputation and happiness, (Lusted, 2010), a large part of the population has not yet accepted this type of intervention and does not intend to undergo cosmetic surgery.

From the available literature, one could not conclude what factors affect patients during the formation of one's intention to undergo cosmetic surgery. Some authors have attempted to identify factors that influence the decision of the patient to undergo cosmetic intervention. Among these factors stand out dissatisfaction with some parts of the body, feeling unattractive, lower self rating, gender, education and culture, aging anxiety, and previous experiences among friends (Brown et al. 2007; Davis, 2013; Von Soest et al. 2006, Haas, 2008; Slevac and Tiggemann, 2010; Delinsky, 2005).

In addition to undeniably important role played by these factors in the determination of the subjection of aesthetic interventions are omitted some important factors relating to subjective norms and perceived behavioural control, as important factors preceding behaviour.

As noted by Sarwer et al. (2004), numerous factors may be contributing to this increase in popularity, including advances in surgical procedures, lower costs and higher disposable income of patients, and increased emphasis on physical appearance. Moreover, individuals are increasingly exposed to the possibility of cosmetic surgery through their social networks. Media coverage of cosmetic surgery is now commonplace, as advertisements promise enhanced attractiveness, magazines tout the latest developments in surgical procedures, and television reality shows celebrate physical makeovers. Psychological research on cosmetic surgery has focused on patients' expectations and satisfaction regarding surgical outcomes. However little is known about attitudes regarding cosmetic surgery more generally. Questions about cosmetic surgery attitudes among the general population, the degree to which they are changing over time, and the factors related to such attitudes, remain largely unexplored. In this paper, we present the development of the methodology for exploring factors that affect people's intention towards cosmetic surgery that will allow researchers to more readily pursue this issue.

2. METHODOLOGY

The Theory of Planned Behavior, proposed by Ajzen (2006) was applied. The Theory of Planned Behavior – TPB, (Fig. 1) offers a framework for understanding and predicting behavior based on three constructs that influence behavior (Ajzen 1991; Ajzen and Fishbein, 1980). The TPB has been used extensively to predict various kinds of behaviors, including health behaviors. Godin and Kok (1996) made a review application in explaining the different behaviors in the medical field including screening, eating, exercising, addictive behavior, use of condoms, HIV/ AIDS, and oral hygiene.

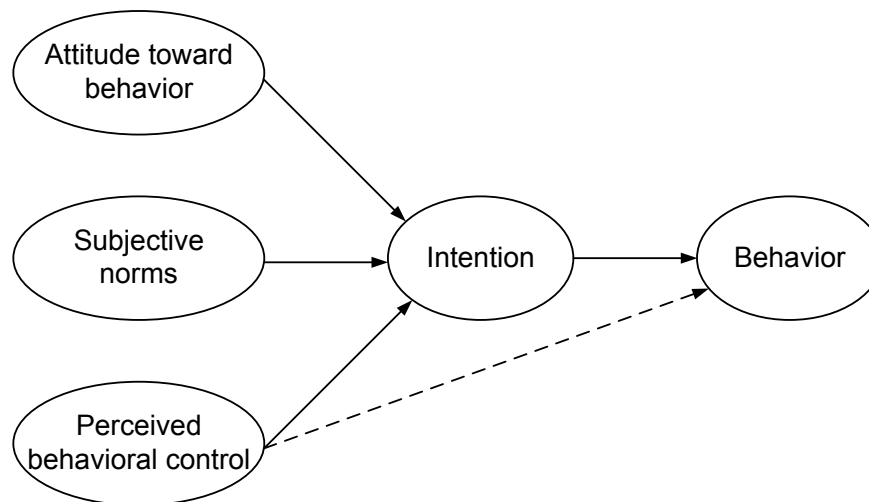

Figure 1: Theory of planned behavior (Ajzen 1991; Ajzen and Fishbein, 1980)

The theory of planned behavior postulates three conceptually independent determinants of intention: (1) attitude toward the behavior - refers to the degree to which a person has a favorable or unfavorable evaluation or appraisal of the behavior, (2) subjective norm - refers to the perceived social pressure to perform or not to perform the behavior, and (3) behavioral control - refers to the perceived ease or difficulty of performing the behavior and it is assumed to reflect past experience as well as anticipated impediments and obstacles (Ajzen 1991; Ajzen and Fishbein, 1980).

Authors developed questionnaire in order to measure direct constructs of TPB related to the intention to use cosmetic surgery services. Questionnaire was distributed to 631 people in period from February to March of 2014th. Of all respondents, 53.7 percent were woman and 46.3 percent were man ($M = 1.46$, $SD = .499$), years between 20 and 63 ($M = 31.61$, $SD = 10.139$). Most of them (93.2%) never had cosmetic surgery before ($M = 1.93$, $SD = .252$), but 81.2 percent, knew someone who had ($M = 1.19$, $SD = .394$). For the analysis of data obtained from the questionnaire was used SPSS software.

Respondents attitude toward cosmetic surgery services was measured using nine semantic differential scales (Undergoing cosmetic surgery would be healthy; Undergoing cosmetic surgery would be useful; Undergoing cosmetic surgery would be profitable; Cosmetic surgery would help me feel more satisfied; Cosmetic surgery would help me feel more confident) scored from -3 to +3 ($\alpha = .913$).

Subjective norms was measured using four items (Opinion of people close to me is important when deciding on cosmetic surgery; I think that my family and close friends would support me to undergo cosmetic surgery; I think that my partner would support me to undergo cosmetic surgery) scored from -3 to +3 ($\alpha = .775$).

Perceived behavioral control was measured using two items (If I had the money, I would undergo a cosmetic surgery; I expect to be able undergo some cosmetic surgery in the future) scored from -3 to +3 ($\alpha = .909$).

Intention to undergo cosmetic surgery was measured using twelve items (i.e. I would like to undergo cosmetic surgery; I intend to undergo cosmetic surgery; I would like to undergo cosmetic surgery soon; I intent to undergo cosmetic surgery soon; I would undergo cosmetic surgery in order to remove some congenital defect) scored from -3 to +3 ($\alpha = .904$). The variable score was calculated for each construct by obtaining the mean score for all questionnaire items included under that construct. On fig. 2 is represented by the structural model intentions to undergo cosmetic intervention.

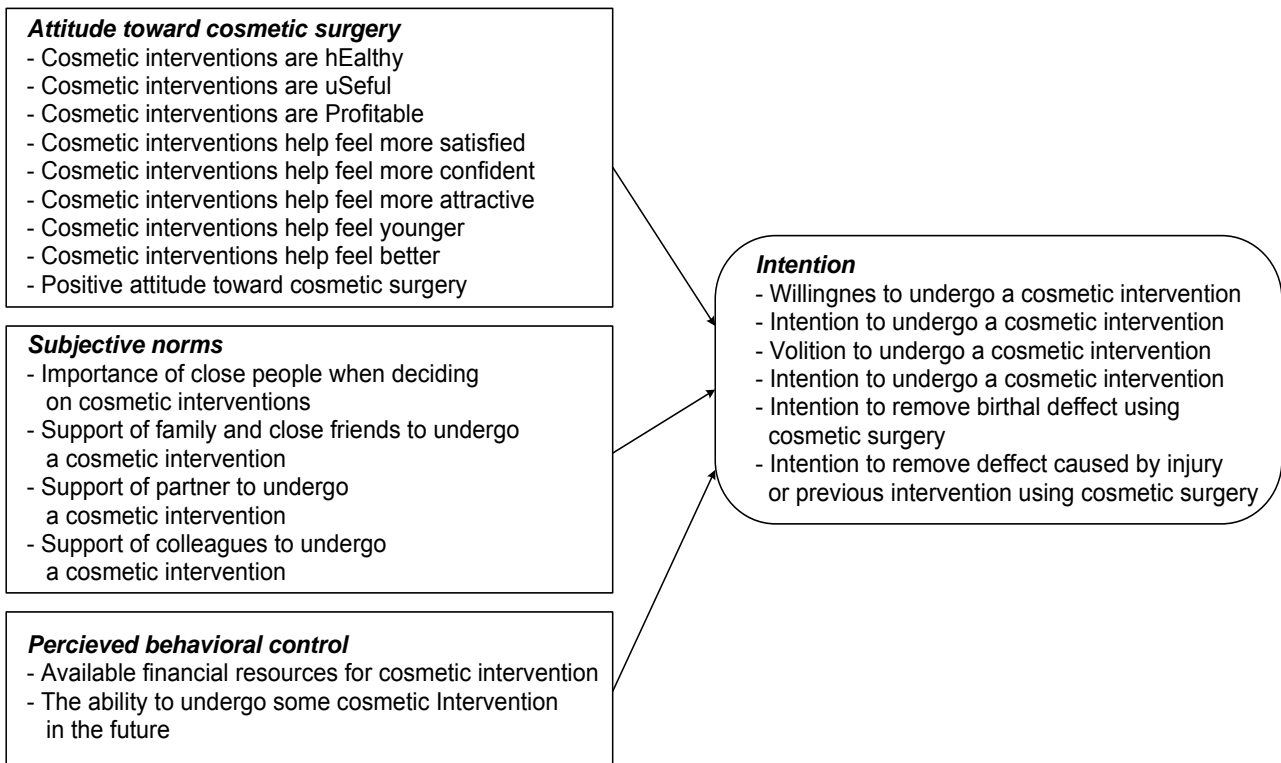

Figure 2: Structural model of intention to undergo a cosmetic intervention

3. RESULTS

To the test the model, and examining how the combination created scale that can predict (attitudes toward cosmetic surgery, subjective norms, and perceived behavioral control) intention to undergo cosmetic surgery, was used linear multiple regression (Fig. 3). Preliminary analyses were conducted to ensure no violation of the assumptions of normality linearity, multicollinearity, and homoscedasticity.

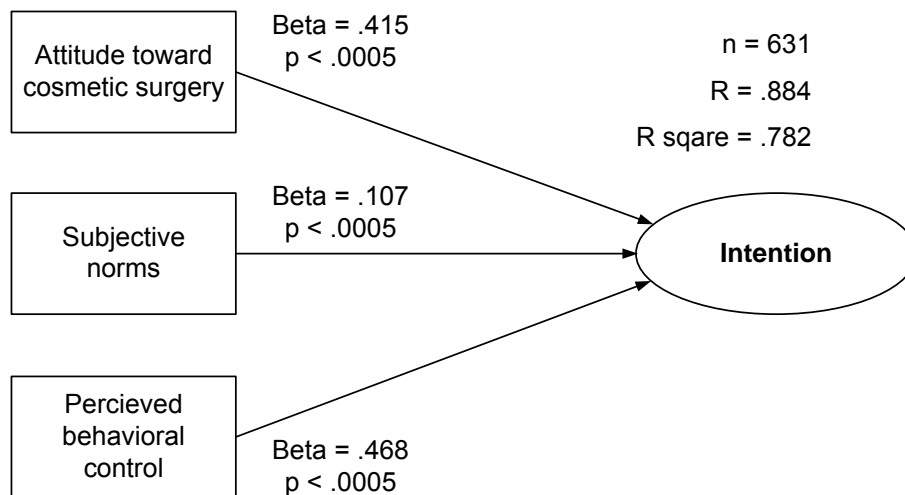

Figure 3: Results of multiple linear regression

The model reached statistical significance ($F [3, 627] = 748.658, p < .0005$), and explains 78.1% variance of the intention toward cosmetic surgery ($R \text{ square} = .782$). Perceived behavioral control had the greatest influence ($\text{Beta} = .468, p < .0005$), followed by attitude toward cosmetic surgery ($\text{Beta} = .415, p < .0005$), and subjective norms ($\text{Beta} = .107, p < .0005$).

4. CONCLUSION

Analysing the previous works dealing with the factors that influence undergoing cosmetic interventions, it can be concluded that the majority focused on motivational factors that drive people to think and want this type of intervention. Von Soest et al (2006) think that body image, teasing history, acceptance of cosmetic surgery in the individual's environment, and self-monitoring are in relation to motivation for undergoing cosmetic surgery. Brown et al. (2007) emphasize that factors that affect the likelihood of undergoing cosmetic surgery lower self-ratings of physical attractiveness and the vicarious experience of cosmetic surgery. Haas (2008) stands the importance of education and culture, as predicting factors in the decision to undergo cosmetic surgery. Slevac and Tiggemann as the main factors that influence the position of the plastic surgery point body dissatisfaction, appearance investment, aging anxiety, and media variables.

All these factors are primarily involved in the formation of attitudes towards cosmetic surgery as an option that gives them the opportunity to rectify their shortcomings, and to restore youthful appearance and beauty. These authors are the factors looked at in isolation and analyse their individual impact on the acceptance of cosmetic surgery, with the lack of a comprehensive approach to the analysis of behaviour in deciding subjecting aesthetic interventions.

It can be concluded that they were not analysed some of the most important factors that influence the intention to undergo cosmetic surgery such as subjective norms, which constitute an important dimension in the psychological process that precedes behaviour, as well as a perceived behavioural control, or the availability of these services to potential patients.

In this work, the authors present an analysis of previous reference works, dealing with the factors that influence the acceptance of cosmetic surgery and, following the example of Theory of Planned Behavior, developed a model for exploring factors that affect peoples' intention towards cosmetic surgery. According to the authors' knowledge, this is the first application of Theory of Planned Behaviour in the field of cosmetic surgery, and the results contribute to the understanding of the intentions of people to undergo cosmetic interventions.

The present study contributes to identifying and understanding numerous factors that together influence one's intention to undergo a cosmetic surgery. That way the results provide the valuable basis for creating strategies and tactics to increase the intention of people to undergo cosmetic surgery.

REFERENCES

- Ajzen, I. (1991). The theory of planned behaviour. *Organizational behaviour and human decision processes*, 50(2), 179-211.
- Ajzen, I. (2002). Constructing a TPB questionnaire: Conceptual and methodological considerations. Retrieved from: http://chuang.epage.au.edu.tw/ezfiles/168/1168/attach/20/pta_41176_7688352_57138.pdf.
- Ajzen, I., & Fishbein, M. (1980). *Understanding attitudes and predicting social behaviour*. Englewood Cliffs, New Jersey: Prentice Hall.
- Brown, A., Furnham, A., Glanville, L., & Swami, V. (2007). Factors that affect the likelihood of undergoing cosmetic surgery. *Aesthetic Surgery Journal*, 27(5), 501-508.
- Davis, K. (2013). *Reshaping the female body: The dilemma of cosmetic surgery*. New York, United States: Routledge.
- Delinsky, S. S. (2005). Cosmetic Surgery: A Common and Accepted Form of Self-Improvement? 1. *Journal of Applied Social Psychology*, 35(10), 2012-2028.
- Elliott, A. (2008). *Making the cut: How cosmetic surgery is transforming our lives*, London, United Kingdom: Reaction Books.
- Godin, G., & Kok, G. (1996). The theory of planned behaviour: a review of its applications to health-related behaviours. *American journal of health promotion*, 11(2), 87-98.
- Haas, C. F. (2008). Motivating factors for seeking cosmetic surgery: a synthesis of the literature. *Plastic Surgical Nursing*, 28(4), 177-182.
- Lusted, M. A. (2010). *Cosmetic Surgery*. Edina, Minnesota: ABDO Publishing Company.
- Lorenzo, G. L., Biesanz, J. C., & Human, L. J. (2010). What Is Beautiful Is Good and More Accurately Understood Physical Attractiveness and Accuracy in First Impressions of Personality. *Psychological Science*, 21(12), 1777-1782.
- Rankin, M., Borah, G. L., Perry, A. W., & Wey, P. D. (1998). Quality-of-life outcomes after cosmetic surgery. *Plastic and reconstructive surgery*, 102(6), 2139-2145.

- Rinzler, C. A. (2009). *The encyclopedia of cosmetic and plastic surgery*. New York, United States: Facts on File Inc.
- Sarwer, D. B., & Crerand, C. E. (2004). Body image and cosmetic medical treatments. *Body image*, 1(1), 99-111.
- Slevec, J., & Tiggemann, M. (2010). Attitudes toward cosmetic surgery in middle-aged women: Body image, aging anxiety, and the media. *Psychology of Women Quarterly*, 34(1), 65-74.
- Von Soest, T., Kvaalem, I. L., Skolleborg, K. C., & Roald, H. E. (2006). Psychosocial factors predicting the motivation to undergo cosmetic surgery. *Plastic and Reconstructive Surgery*, 117(1), 51-62.

KEY ACCOUNT MANAGEMENT - STRATEGIC IMPERATIV IN POSTAL SERVICES

Spasenija Ožegović¹, Dragana Šarac², Marija Unterberger³

¹PE Post of Serbia, sozegovic@ptt.rs

² University of Novi Sad, Faculty of technical sciences, Novi Sad, dsarac@uns.ac.rs

³ High traffic school „Pinki“, Novi Sad, marijaunterberger@gmail.com

Abstract: *Many modern companies around the world are trying to maintain competitive advantage through development of modern Relationship marketing (RM) program and other programs which provide customer loyalty. Because of the specific characteristics of postal traffic and postal services, one of the recommended programs and strategies for maintaining and nurturing long-term profitable relationships with selected group of strategic customers/users of postal services is a modern marketing management strategy of Key Account Management (KAM). It is a strategic decision and the imperative to improve competitiveness and business performance success of contemporary participants, both at the global postal market and the postal market in Serbia. In this paper we present the framework of the modified KAM model in postal traffic, which has not yet been exploited. Marketing management research, testing the possibilities its application were performed in the selected company, PE Post of Serbia, the undisputed leader in the postal market in Serbia. Developed and presented KAM methodology for the postal service can be one of the best solutions that contribute to the successful future development and transformation of the postal sector.*

Keywords: *strategic model, key account, postal services, marketing management*

1. INTRODUCTION

The process of KAM, combined with a comprehensive Customer Relationship Management (CRM), will provide increased sales from 20 percent of customers who represent 80 percent of revenues to organisation, and more importantly, will ensure a key basis for the successful development Key Account Management (KAM). KAM is not a matter of choice of management company already strategic imperative of modern business. However, many companies still do not understand how to develop a strategy for working with key customers, as well as which tools to use in order to ensure the delivery of complex solutions to key customers and develop and improve long-term profitable partnerships (Filipović and Kostić, 2003).

The main point of view of science and practice today, represent the activities directed towards the establishing, developing and in maintaining successful business relationships with customers. In the early 1980s, parallel to the development of new marketing paradigm – the relationship marketing, the concept of KAM was also developed as a specific relationship marketing program that is focused on selected group of strategically significant customers, key account. In the context of development and advancement of the concept of KAM in the postal services in the Republic of Serbia, the application of modern and modified strategic management scenarios, models, techniques and tools is proposed (Ožegović et al. 2013).

In this paper, KAM was viewed as a multi-phase strategic management process, while its application is based on the postulates of *Project Management*. The primary objective of this study is to develop a modified multi-phase strategic model Key Account Management in the postal services. The model presented in this paper is called “**PostAIM**” (Ožegović, 2010). This multiphase and multidisciplinary model approaches the problem from analytical, organizational and technological aspects. The model implies that the focusing of strategy and activities is performed before, during and after the process of sale. This approach has not been used yet and, with it, “**PostAIM**” can be considered as the original model for key account management. The applicability of this model in the postal services has been confirmed during the research in the Republic of Serbia. This paper presents the results of the application of “**PostAIM**” model as well as the model of “customer value” to the postal services, dubbed “**PostPPA**”. Model “**PostPPA**” (Ožegović, 2010) was used during the realization of selection process and categorization of customers in postal services. Testing the proposed modified model for key account management was performed in selected postal services company, PE Post of Serbia, using data from four main sources: data from the company's business reports, managers and sales teams, data obtained on the basis of the survey and interviews with managers at all levels and the data collected based on interviews with managers responsible for customer care and sales teams, goals and views of strategically important customers involved in the research which was conducted in the period from 2010 to 2012 in order to create a solid basis for building the proposed model for key account management in

postal services. During the research to identify critical success factors of KAM, the study identified the special importance of the quality of services, personnel responsible for care of customer, support of top management, while in contrast to studies done in Taiwan (Chun et al., 2009) a very small influence of geographic factors was observed (p.803).

2. RESEARCH METHODOLOGY

The primary objective of this research is to improve current models for managing key account in postal services. KAM methodology, with whose research dealt McDonald M, Rogers B, Woodburn D, Capon N, Pardo C, Cheverton P, Kotler Ph, Millman T, Wilson K, so far did not have an important application in the postal services. Based on the research, analysis and comparison of the results obtained and presented in the works of these authors, a modified model for key account management in terms of management process was proposed. Such modified model can be applied to the postal services. The outline of proposed Ožegović and Šarac (2012) point out that modified KAM model is based on the methodology of project management. In order to verify the implementation of the new model, a case study method was used. We came to most findings in the research using the test methods, conducted through structured interviews and surveys, which are often used in research on the behavior and attitudes of customers, markets, customer and seller relationship, as well as all relevant information to cause or result from these relationships.

The purpose of the research in the selected company postal services was to make a ranking of key customers at market elements and the level of profitability that is achieved, as well as investment in building long-term relationships with key customers of postal services. Based on the results of research and comparative analysis of existing models of management to key customers was developed a model of key account for postal services.

For the purpose of research conducted in the period 2010-2012 was established three representative samples: The first established the pattern (systematic, stratified) included 106 managers at all levels of management in the selected company postal services. This pattern is formed so that it has the basic set (all managers) previously divided the membership manager management level (top, middle, operational) to be followed by each of the three strata (randomly) selected by 50% of the total manager of that level in the sample for the management level. The second sample (systematic, deliberate, quota-sample) participated in 53 companies (customers) based on the percentage of participation in the annual income of sales. In this study used a semi-standardized interview *face to face* as a method tests. The aim of this study was to determine the attitudes of selected customers group to the importance of certain factors of success offered by KAM for the purpose of their comparison and cross tabulation of the results that were obtained, the same issues in the company's vehicles postal services. Conclusions which have been adopted are (the resulting conclusions are presented) a significant starting point for the formulation of methodologies and models for managing key accounts in the postal traffic. The third sample (systematic) included 56 companies of customers of postal services, with areas of southern Banat. In this study, we used a modified questionnaire UPU, and data collection was done by mail (Self-completion Questionnaires and Mail). The aim of this study was to determine the level of satisfaction of the user groups, as well as their views on the quality and competitiveness of the postal service used. The results of this research support the claim stated confirming the hypotheses, the formulation and development of management strategies to key customers based on customer satisfaction and profitability. All questionnaires were processed using specially developed software solutions in line with the objectives of these studies, on the basis of terms of reference drafted by the author of this paper.

3. THE NEED TO MANAGE KEY ACCOUNT IN POSTAL SERVICES IN THE REPUBLIC OF SERBIA

Majority of large postal service organizations are mainly divided into business units established on the basis of their subject criteria or territorial criteria. Managers of modern organizations are challenged to successfully coordinate the activities of these units and use their knowledge and business skills for the benefit of the organization as a whole. Very often the work of these business units is not in sync and in line with the mission and purpose of the organization. Key account management is one of the most important changes in selling that has emerged during the past two decades. KAM is a radically different organizational process used by business-to-business suppliers to manage their relationships with strategically-important customers, and it produces measurable business benefits" (Lynett, 2012).

KAM in postal services represents a modern strategy and marketing management approach that is based on building and nurturing long-term profitable relationships with strategically important customers in order to achieve mutual benefit for companies involved in this business relationship.

Due to the prevailing competition in the market of communication and distribution of goods, many companies build stronger and closer relationships with key customers. However, many companies still do not sufficiently understand how to develop strategies for working with key customers and which tools have to be used in order to achieve and improve their competitiveness. Key account management assumes consideration of mutual interest of both customer company, and on the part company of the seller as well as inter-organizational coordination at all levels, Table1.

Table1: Mutual key benefits of key account management in postal services

<i>Key benefits for the vendor company in postal services</i>	<i>Key benefits for key customers</i>
Long-term increase in profits and competitiveness	Better information on postal services
Joint appearance – joint bid with customers	Increase of delivered value
Improving knowledge about customers	Better understanding of the level of charges for postal services
Close business relationships	The reduction in input costs
Better information about the competition	Better knowledge about the benefits of service for the customer
Measurable levels of objectives achievement	Capacity to build individual customer profiles
Association of business plan and strategies	Guaranteed execution of services in cases of limited resources of the seller company
Creating complex business solutions to identified problems of key customer	

Ožegović (2010) emphasize the importance creating the mutual long-term benefits for related companies (p.85). According to the results of conducted research during the development of the model in the selected company of postal services, Post of Serbia, the public postal operator and leader in the postal services in the market of the Republic of Serbia, it is concluded that there is a need for key account management in the postal services because:

- Less than 5% of customers generate about 79% of revenue;
- Competition develops modern strategy for key account management;
- About 70% of total customer servicing cost generate customers who earn less than 20% of revenue;
- There is a need for allocation of company's available resources;
- Strategically important customers of postal services believe that single postal and other services intended for mass customers do not constitute an adequate response to their needs, etc.

The power of the small number of major market participants is notably increasing. Well known Pareto principle, 80/20, can be applied in postal traffic. Namely, approximately 20% of participants achieve about 80% of total turnover in one branch, that is, the postal sector. They require special treatment.

In this balanced inter-organizational relationship value, **key customers should not be identified with "big buyers"** who, with planned management activities, can over time be converted into a group of potential key customers. Key customers are strategic partners with whom the success is achieved and shared. There cannot be many, neither that type of relationship can be determined in advance.

Key account management in the postal service using the above definitions, is a modern business concept based on building and nurturing long-term profitable relationships with strategically important customers, in order to improve the competitive power and increase profitability, both on the side company of postal services and on the side of company's key customer.

4. METHODOLOGY OF KEY ACCOUNT MANAGEMENT IN POSTAL TRAFFIC

In accordance with the primary objective of this study and presented key research results, the proposed methodology for KAM in the postal services, whose function is to formulate the framework of the strategic model for key account management.,,PostAIM“ developed by Ožegović (2010) is the result of modeling and essentially defines key account management as a single whole. It is designed on the basis of scientific knowledge on the management of key customers and "good practice" to be enforced widely, primarily with

the postal service, as well as in other activities of service sector. This model is based on the fact that key account management is a multi-stage strategic management process.

In accordance with this methodology and based on we present only the framework of developed model for KAM in postal services, named „**PostAIM**“ which is based on the application of the same. Framework of this model is presented through 3 key management processes: Analysis and planning, Implementation and monitoring, Figure 1.

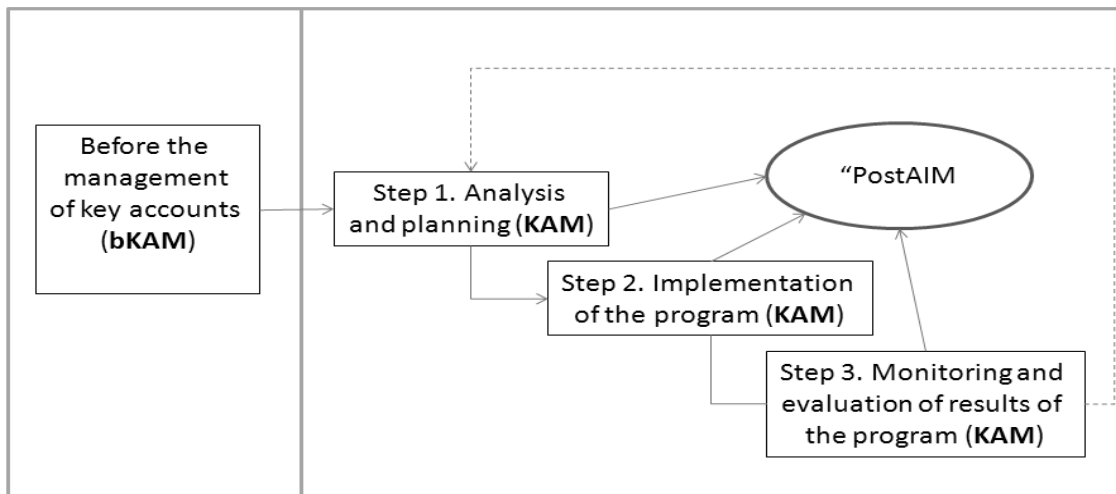

Figure 1: Suggested framework of modified strategic multiphase management model of KAM in postal traffic “PostAIM” (Ožegović, 2010)

In addition to these three key management processes (**A**nalysis and planning, **I**mplementation and **M**onitoring) that occur by the “step by step” system, the proposed methodology for key account management, based on a multiphase model of key account management, defines and conditions the progress of the following processes:

- adoption and management of ethical issues and norms of relations and possible conflicts,
- establishment and analysis of management accountability in the process of key account management, primarily based on developing and maintaining successful, profitable and lasting relationships with key customers, and
- establishment of accountability and the creation of management models for managing the cost and benefits in order to ensure achievement of optimum effects in the of key account management.

During the process of modeling „PostAIM“, another model of “**customer value**” has been developed, called “**PostPPA**” (Ožegović, 2010) which was used as a new approach for the realization of the process of identification, selection and categorization of key customers in the postal service, as one of the key processes of KAM, because its application is to determine which potential customers will obtain the status of key account, as well as the strategies that will be applied based on the portfolio of key customers towards a certain categorie of customers (Ožegović and Šarac, 2012).

A preliminary categorization of customers in the selected area could be carried out by customer classification into A, B and C category by using the known Pareto 80/20 rule. In determination of criteria of identification, selection and categorization of strategically important customers, key customers, that is customer value for the selected company we have used the following criteria: profitability of key customer, share in revenue from sales, attractiveness. Identification of key customers as customers with the highest value level, that is, the highest impact on performance indicators and competitiveness. In formulating the model for segmentation of customers, we started from the fact that the value delivered to key customer is critical for KAM (Pardo et al, 2005). The proposed model “**PostPPA**” a general **model for calculating the total value of the customer (Vk)** as the basis for segmentation of customers in the postal services companies, can be represented by the following expression:

$$V_k = \sum_{i=1}^n t_i \cdot p_i \quad (1)$$

t_i- weight of i-th element

p_i- coefficient (calculated or estimated value)

$$V_k = t_{up} \cdot p_{up} + t_{pfk} \cdot p_{pfk} + t_{pak} \cdot p_{pak} \quad (2)$$

Where are:

V_k – coefficient of customer value

p_{up}- % share in total income

p_{pfk}-% of customer profitability

p_{pak}- % of assessed customer attractiveness

t_{up}- weight factors of customer participation in the total income

t_{pfk}- weight coefficient of customer profitability

t_{pak}- weight coefficient of the estimated customer attractiveness

$$t = 0,3;0,5;0,2 \quad (3)$$

$$V_k = 0,3 \cdot p_{up} + 0,5 \cdot p_{pfk} + 0,2 \cdot p_{pak} \quad (4)$$

During the implementation of complete process of identifying key customers, as well as on the basis of obtained results, it can be concluded that the biggest customers are often not the most profitable customers, because the distribution of customers in the ranking, following the procedure of their selection using the proposed model “PostPPA” has considerably changed. Most profitable customers are usually a little behind the biggest customers because they cause lower costs. Based on received indicators, ranking of preliminary categorized customers has finally been made and identifies 25 potential key customers in selected postal services company, Figure 2. The results of numerous studies suggest the conclusion that the optimal number of key customers is between 20 and 30 (Ryals and Rogers, 2007; McDonald and Woodburn, 2007; McDonald et al, 2000; Pardo and Ivens, 2008).

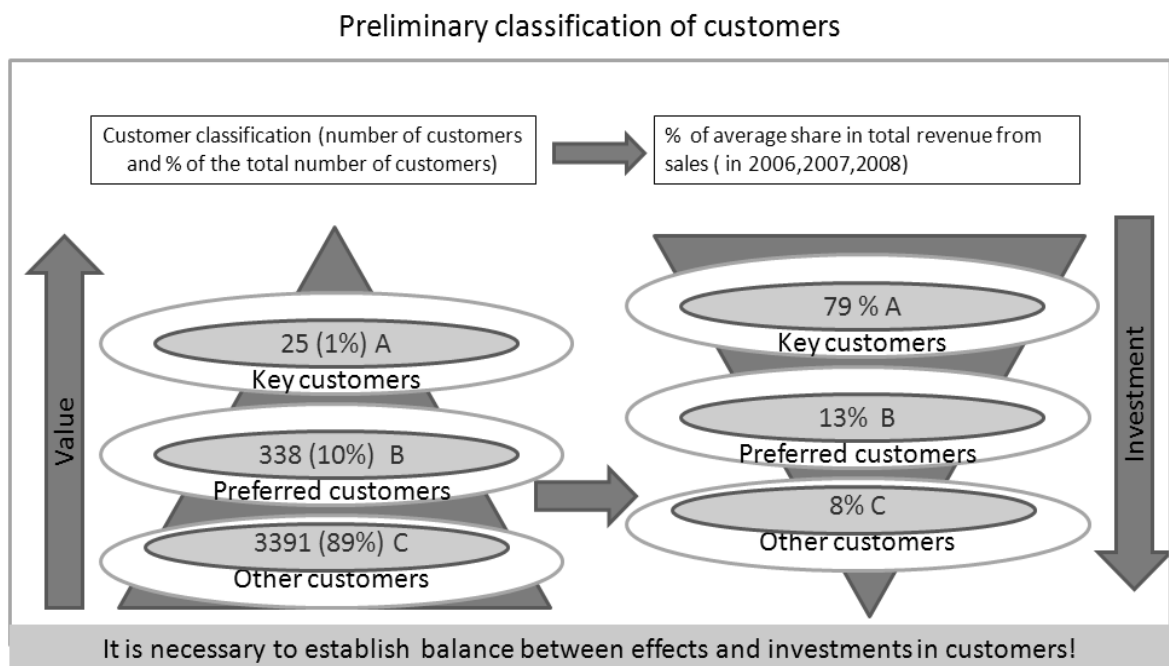

Figure 2: Pyramid of customers in the selected postal services company in B2B market and the Pareto principle 80:20

Identified a number of potential key customers during the research complies with best practices and research results published in the world for the number of key customers. The reason for this situation is contained in the fact that KAM is much more than a dedicated business relationship. In order to meet key buyers, it usually means supply them with highly customized business solutions, rather than existing products and services, which require significant investments throughout the organization. In addition to the proposed method for determining the cost of customers, same can also be determined by cost per process/activity

specific to customers with an essential condition, namely the existence of systems for accounting costs based on activities (*Activity Based Costing – ABC System*).

In accordance with the adopted methodology, testing the application possibility of the proposed modified model of the author, "PostPPA" was conducted in the Post of Serbia on identified potential key customers. After application of the model "PostPPA" positions of key customers in the ranking have changed significantly compared to the previous one, which was the aim and purpose of the same.

KAM as a strategy represents an integral part of RM concept. This is also strategic approach used by companies to implement the principles of RM into their policy and strategy towards customers.

5. CONCLUSION

"The Post is starting rank awareness and knowledge of the human mind, a means for the exchange of material and cultural goods, a supporter of peace and goodwill among people and nations, the messenger of sympathy and love, a mediator between separated friends, the Comforter the bereaved and the lonely soul, the connection between separated family members, a reflection of the joy of of society in which we live." (Jullus Juhlin, president of the VIII Congress of the UPU (Universal Postal Union - UPU), Stockholm, in 1924).

Postal service companies should establish management activities for key customers through the process of planning strategic business relationships that will provide insight into the status of a key customer, collecting and analyzing data, setting measurable goals and accountability. After developing criteria for identifying key customers, we decided to adopt and develop the concept of key account management, based on the proposed model, to ensure that other key elements of the strategy (systems, processes, organization) are aligned. The organizational structure should allow flexibility and creativity of professional managers for key customers in the application of modern business concepts. The role of top management should be directed at understanding the benefits that can provide the application of key account management concept, while at the same time understanding their own opportunities and risks. The implementation of continuous training and training of personnel while implementing the system of incentives would create the essential preconditions for supporting and improving the key account management. Managers of key customers are expected to be flexible, intelligent, stable, open to customers, skilled in communication and able to avoid conflicts. Strategy for key account management in postal services may be effective only in situations where there has been inter-organizational alignment of requirements and expectations of key customers and the organization of postal services. We have come to the conclusion that the proposed KAM model is applicable in the postal service and that it provides the following key results:

- Provides efficiency and effectiveness in the process of segmentation and categorization of customers;
- Provides identification of key customers based on marketing criteria and profitability;
- Contributes to lowering of risks as a result of wrong choice of customers in which should be invested;
- Allows definition of objectives and choice of optimal strategies for each key customer, as well as their alignment with corporate strategic objectives and capabilities of the company;

Results of the research possibilities of the proposed modified model of managing key accounts in the postal service, confirmed the hypothesis that effective governance model key customers based on the performed segmentation and categorization of customers based on pre-established criteria and the level of marketing profitability.

The growing importance of key accounts, and the question of how to realize mutual benefits of partnership relations, suggests that the management of relationships with key client area of vital importance for further marketing research management.

REFERENCES

- Chun, H., Chi, H., Yen-hui, O. (2009); A study of critical factors of the job involvement of financial service personnel after financial tsunami, Take developing market (Taiwan) for example, *African Journal of Business Management* Vol. 3 (12), pp 798-806
- Filipović, V., Kostić, M. (2003): *Marketing menadžment*, FON, Beograd
- Lynett, R., (2012); How to Succeed at Key Account Management, <http://blogs.hbr.org/2012/07/how-to-succeed-at-key-account/>; ac.; 01.01.2014.
- McDonald, M., Woodburn, D., (2007). *Key Account Management-The definitive guide*, (2nd ed.). Elsevier
- McDonald, M., Rogers, B., Woodburn, D., (2000). *Key Customers: How to Manage Them Profitably*, Oxford: Butterworth-Heinemann
- McDonald M., Woodburn D., (2007): *Key Account Management-The definitive guide*, Second edition, Elsevier Ltd.
- Ožegović, S. (2010); *Key Account Management in postal services*, Unpublished doctoral dissertation. Faculty of Organizational Sciences (FON), Belgrade
- Ožegović, S., Šarac, D. (2012); Exploring the possibilities of application of the modified multiphase strategic model for Key account management in postal services, *African Journal of Business Management*, Vol. 6(14), pp. 4964-4973
- Ožegović, S., Šarac, Kujačić, M. (2013); The Organizational Aspects of Key Account Management in Postal Traffic, *Tehnics*, special edition, pp.97-103.
- Pardo, H, Ivens. B.S (2008), Key-account-management in business markets, *Journal of Business & Industrial Marketing*, Vol. 23 , Number 5 , pp.301–310
- Pardo C., Henneberg S., Mouzas S., Naude S., (2005): Unpicking the meaning of value in Key Account Management, University of Bath school of Management, Research 2005.02.
- Ryals L, Rogers B (2007), Key Account Planning, Benefits, Barriers and Best Practice, *Journal of Strategic Marketing*, Volume 15, Numbers 2-3, May 2007, pp.209-222

ROLE OF MARKETING COMMUNICATION IN CANCER PREVENTION

Jelena Cvijović¹, Milica Kostić - Stanković², Goran Krstić³

¹ University of Belgrade, Faculty of Organizational Sciences, jelenacvijovic85@gmail.com

² University of Belgrade, Faculty of Organizational Sciences, milicak@fon.rs

³ Serbian Railways Medical Centre, gorankrstic85@gmail.com

Abstract: *Considering the current statistics, it can be concluded that Serbia is one of the countries with a high rate of incidence of different cancer types, which represents the alarming problem nowadays. Innovative marketing campaigns and promotional activities can successfully contribute the improvement of public health by raising level of general knowledge about health issues and benefits that change of habits, eradication of undesirable behaviour and regular checks and controls have. The focus should be on continuous marketing campaigns that include mass communication through various media - television, radio, print, internet or direct communication between medical staff and patients.*

Keywords: *promotion, marketing communications, health care, cancer prevention, information, education, media*

1. INTRODUCTION

Current statistics indicate that, worldwide, every two minutes one woman dies of cervical cancer. Globally, cervical cancer is the third most common cancer type in women - every year approximately 500 000 women are being diagnosed with it, and more than half of that number die from that disease (Ferlay et al., 2010). The disease is especially common (80% of the overall number of diagnoses) in less developed regions where there is no organized prevention programs. According to the data pertaining to Serbia, cervical cancer represents the cause of 6% of all deaths in women in Serbia. Serbia has the highest incidence of cervical cancer (24.3 to 100 000) in relation to all the other republics of the former Yugoslavia and one of the highest prevalence among the countries of South Eastern Europe. The incidence of cervical cancer in Serbia is two times higher than the incidence in Western Europe (10.43 per 100,000 women) and about three times higher than in the EU countries (where the figure is 8.1 per 100,000 women). Age representation of cervical cancer shows a typical increase after the age of 30, with the most common detection in the age groups from 45 to 49 and from 70 do74 years. When it comes to breast cancer in the world, each year about 400,000 women are being diagnosed with it and about a million of them die from it. In Europe, about 129,000 die each year, and about 370,000 women are diagnosed. Breast cancer is the most common malignant tumour in women in Serbia. There are about 4,000 new cases every year and about 1,600 of them die, which makes 18% of overall number of deaths from all cancers types. Statistics indicate that one in eight women either already has breast cancer or will become ill during lifetime (Jankovic et al., 2004).

Such prognoses indicate the necessity of introducing marketing communication into the area of public health in order to inform and educate public about methods of prevention and early detection of cancer (Plsek and Wilson, 2010). Although developed countries place greater attention to intensive and continual media campaigns dedicated to health promotion, in Serbia still dominate conventional approaches, which are related to the rehabilitation and cancer treatment rather than to disease prevention. By creating awareness about the possibilities and ways of application of certain preventive measures, the mortality rate of certain types of malignancies, including breast and cervical cancer, would be significantly reduced. The focus of activities in health care should switch from reactive to proactive activities - health promotion and prevention activities in which marketing communication can have significant role.

2. PREVENTION AS A BASIS FOR IMPROVING PUBLIC HEALTH

Significant political, economic and social transformation at the global level that have taken place in recent decades, have caused major changes in the conception and organization of health care. One consequence of the above mentioned transformation is making increasing efforts to improve and enhance public health. There are three main aspects of prevention activities. The first aspect focuses on preventing or reducing the incidence of risky behaviour (such as poor eating habits, smoking, heavy using of alcohol and the like) and requires education of the public about the possible consequences. The second aspect relates to the promotion of health-protective behaviours, such as screening, immunization and regular check-ups or acquiring certain skills, for example, ways how to perform breast self-examination. The third approach involves the impact on legal authorities, in order to ban some dangerous issues (smoking in public places to

protect non-smokers from the effects of passive smoke inhalation, banning of GMO food, ecologically unfriendly products etc.) (Killoran and Kelly, 2004; Kelly et al., 2004).

The goal of improving public health is enabling individuals to gain greater control over their health and its determinants. For example, many activities in the area of health improvement are directly related to (Watson and Platt, 2002):

- Communication and health education - strategies that are used to increase knowledge and awareness of the public so that individuals can make rational decisions regarding their own lives and health. Evles and Simnett (2003, p.27) emphasize the necessity of using mass media to inform the general public about health practices; distribution of flyers and leaflets on health care, conducting of special programs for vulnerable social groups, etc.
- Training and consulting – ways of how medical practitioners can enable patients to develop the necessary skills for early detection of some diseases.
- The development and involvement of the wider community and capacity building - the fundamental forms of social organization and collective action aimed at improving public health.

Rifkin (2003), one of the well-known theorists of improving of public health, identified the five most important aspects in this process:

- The development of personal communication skills of medical staff (for successful education of patients or working with marginalized groups);
- Creating a supportive environment (which provides confidence and respect, especially in schools and workplaces);
- Strengthening actions within the community;
- Construction of adequate public policy that supports initiatives to improve public health;
- Transformation of health services from a reactive to a proactive sphere of action (better balance of resources in order to promote preventive action).

Practice has shown that the problem of improving public health is closely linked to the informing and education and of the population (Labonté and Schrecker, 2007). At the international level, it has been shown that investments in marketing communication about prevention are more significantly associated with improved general health of whole population than economic growth and investment in other social spheres (Labonté and Laverack, 2008). The results suggest that higher awareness level about prevention can lead to improved health outcomes in developing countries (Bratt et al., 2002), such as Serbia.

3. MARKETING COMMUNICATION ON HEALTH PREVENTION

Marketing communication on health prevention includes providing health information with the aim of influencing the behaviour and attitudes of the public and raising awareness about ways to prevent various diseases and potential hazards of unhealthy behaviour (NCHEC, 2007). Roman et al. (2003) indicated that effective communication is the key to prevent disease and reduce health care costs on national and global levels. Marketing communication on prevention involves conveying messages to target groups about the potential risks and nature of diseases, whereby the target group should receive and correctly interpret the message and use information in decision making on individual health care. Messages can be transmitted through direct communication of medical staff with patients or through the mass media if communication demands wider audience (Pérez and Raffy, 2008). If properly planned and implemented, marketing communication in the field of prevention can be very effective, with a tendency to influence the general public and policy-makers and to promote positive change in the community, ways to improve the quality of health services and to attract sponsors and donors from the private sector and create the stimulating partnerships. As the public becomes more informed, changing the social consciousness and recognition of the health problems would arise in the community. In addition to initiating behaviour change or the introduction of new legislation on health care, marketing communication can help other positive changes in the community, such as changes in the physical environment. Such examples include the provision of public space for physical activity and recreation, building bike paths or sidewalks that will allow people to walk more and use transportation means that does not pollute the environment and so on (Pokhrel and Sauerborn, 2004).

There are four factors to be considered when planning and implementing marketing communication campaign about health issues (Nicholson, 2001): the level of health literacy of the target group (ability to receive and understand health information), the level of knowledge and awareness of health and disease, the current attitudes of the target group towards health, disease and prevention and structural barriers (limited access to health care, lack of funding, lack of health insurance, insufficient number of health workers and the like). Cheng, Kotler and Lee (2009) defined following phases through which a promotional campaign aimed at creating awareness about prevention must pass:

- Defining of health problem(s) and the ways of its suppression:

When defining prevention campaigns, it is essential to identify public health problems and summarize the factors that led to the decision on creating that type of campaign. Reasons for the decision may be based on the various research results, epidemiological or scientific data that can quantify defined problem and explain prevention possibilities.

- Analysis of the situation:

By conducting SWOT analyses, some conclusions based on internal factors such as the level of funding support from government and relevant institutions, current partners and sponsors of the campaign, can be drawn. Also, it is necessary to define how to take advantage of opportunities and to eliminate or avoid threats to the implementation of the campaign. In this phase, situational analysis of environmental factors - demographic, psychographic, geographic, economic, cultural, political, legal and technological, is also of essential importance. At this stage it is also necessary to analyse the results of current and previous campaigns, particularly those with similar goals and summarize the main activities that have been conducted, achieved results, positive or negative experiences etc.

- Identification of target group(s):

The selection of target group(s) is done by the segmentation of the public based on certain common demographic, psychographic, geographic and/or behavioural characteristics. After selection of the target group, the current level of knowledge and awareness of its members about specific health problems and prevention possibilities should be estimated by using the knowledge scale, which has following levels: absolute unfamiliarity with the problem, recognition of the problem, basic knowledge, significant knowledge about the problem and absolute familiarity with the problem (Siegel and Lotenberg, 2007).

- Determination of communication objectives:

The objectives are usually applied as: change in behaviour, attitudes and/or beliefs, higher knowledge and information level about health problems etc. Objectives of these type of campaigns are sometimes difficult to quantify, but, for example, can be presented as a greater number of people doing preventive screening, greater number of cancer detections in the early stage etc.

- Creation of a message and determination of appropriate source:

This phase consists of following decisions: what to say (message content), how to say (creative strategy) and who should say it (message source). Generally, messages of this type can be classified into two broad categories - those that include informational or transformational appeal. Informational appeals assume that members of the target group rationally process communication messages and that their behaviour is based on logical reasoning. This type of message is used when the target group has a highly developed awareness of the disease and prevention and is prone to self-initiated behavioural change when there is a real need for that. Transformational appeal is used when attempting to provoke negative or positive emotions of the target group. Many health promoters use negative emotions such as fear, guilt and shame to motivate people to change their behaviour (for example, to take care of the teeth hygiene and go for regular check-ups per year), or to stop doing certain things (for example, to reject smoking or uncontrolled overeating) (Kotler et al., 2008). Selection of proper message source is significant when it comes to health prevention. Three main factors that give more significance to sources are: expertise, credibility and likeability.

- The choice of marketing communications mix:

The choice of an adequate communication instruments ensures that the message reaches the target group. Marketing communications mix is a combination of these instruments, with optimal participation of each of them, which will ensure the achievement of marketing communication objectives (Kostic – Stankovic, 2013). Campaign dedicated to health prevention requires a synergy of the instruments in a way that enables a fully successful communication process.

- Establishing a budget for communication:

The budget for the marketing campaign reflects the cost of development and its implementation, which include those associated with the promotional mix and additional costs anticipated for monitoring and evaluation. Additional funding sources may include a variety of companies, institutions, foundations, media partnerships, donations and sponsorships. Budget must be sufficient to ensure continuity of the campaign and policy of its adoption must be flexible in order to enable adaption to the current changes and situations (Kostic – Stankovic, 2011).

- Measurement and evaluation of the results

Results should be aligned with the objectives set for the campaign. Monitoring is conducted after the beginning of the campaign, but before its completion in order to determine whether adjustments are necessary to ensure that program objectives would be achieved. Evaluation refers to the final report on what was actually achieved through the campaign.

4. EMPIRICAL RESEARCH

The survey based on polling a sample of female patients of the Serbian Railways Medical Centre was conducted in October, 2013. The main purpose of the research was to examine the level of awareness of the respondents about ways to prevent breast and cervical cancer and major channels of communication that are used for informing about those topics.

The sample was structured by age into four groups: from 20 to 29 years (31% of respondents), from 30 to 39 years (21%), from 40 to 49% years (16%) and 50 years or more years (32%). Greater percentage of the respondents (69%) comes from urban areas, while the rest (31%) live in rural areas in Serbia. In terms of education, the approximate percentages of the sample have completed their secondary school education (44%) and higher education (43%), while the remaining 14% have only primary school.

4.1. Results and analysis

The research results indicate that women who belong to the age group of 20 to 29 years, in most cases (51.6 %), gynaecological examination perform annually, while 16.1% do not do such examination at all. More than half of those who regularly go for check-ups always done Papanicolau test (in further text abbreviated as Pap test), approximately 42% sometimes and 6.5% never. When it comes to the age group of 30 to 39, 47.6% of women go to gynaecological examination once a year. About 52% of them regularly do Pap test, 38.1% sometimes and 9.5% never. Approximately 19% of the members of this age group do not go to a gynaecologist at all. Among women aged 40 to 49, the highest percentage (56.2%) goes to annual examinations, the quarter twice a year and 12.5 % never. Pap test regularly does half of them, 37.5% sometimes and 12.5% never. A significant percentage of women who have 50 or more years (71.9%) goes to gynaecological examination once a year, 9.4% twice, and 15.6% never. Pap test always does 59.4%, while 28.1% does that test irregularly and 12.5 % never.

From the perspective of areas that respondents come from, it can be concluded that there are variations in responses. About 56% of women who live in urban areas do gynaecological examination ones a year, 18.8 % twice a year and 14.5 % do not go to such medical examinations at all. Among those who visit a gynaecologist at least once a year, 62.3 % always demand Pap test, 30.4% irregularly and 7.2% never. When it comes to respondents who come from rural areas, 61.3 % go to such examinations once a year, 9.7% twice and 19.4% never. Pap testing regularly does 35.5%, 48.4 % sometimes and 16.1% never. It can be seen that women in rural areas have less developed awareness of performing Pap test on regular basis, which is the main indicator of early cancer stages.

The results indicate the existence of some differences in frequency of performing gynaecological examinations and Pap tests observed by education level. More than half (53.5%) of higher educated women do annual gynaecological examination, 18.6% do such examination twice or more and 9.3% never. A significant percentage (67.4%) regularly does Pap test, 27.9% sometimes and 4.7% never. When it comes to women with secondary education, the survey results indicate that the greatest percentage (65.9%) does annual gynaecological examination, while 13.6% does not. Pap test is a regular item for 54.5% of them, for 34.1% occasional, while 11.4 % do not consider that it should be done. Equal percentages of women who have completed primary school do gynaecological examination ones a year and never (46.2%). Slightly more than 69% of women of this age group are not doing Pap test regularly, while only 7.7% of them do it every year and 23% never.

The results indicate that the largest percentage of respondents from all age categories are familiar with the way of performing breast self-examination: 77.4% of women aged 20 to 29, 71.4% of women aged 30 to 39, 68.8% women aged 40 to 49 and even 96.9% of women who have 50 or more years. The percentage of women who perform self-examination is slightly higher in urban (84.1%) than in rural (74.2%) areas. The awareness of the necessity of performing self-examination increases with level of education. In the group of women with only primary education, the percentage of those who are not familiar with this type of examination is higher - 61,5%. Approximately 80% of women with secondary education are familiar with the way of carrying out this examination, as well as 95.3% of those with higher education. A high percentage of women of all age groups has never performed mammography or ultrasonography: 84% of women aged 20 to

29, 76% of women aged 30 to 39, 63% of women aged 40 to 49 and 43.8% of women that have 50 or more years. The percentage of women who have done mammogram screening is higher in urban areas (37.7%) than in rural (25.8%), but it remains evident that the overwhelming percentage of the women had never performed this type of examination. In the group of women with only primary education, this type of examination has already done 23%, as well as 40% of women with secondary and 30% with higher education.

The largest number of women of all ages has been informed about the possibility of preventing breast and cervical cancer by the media - more than 60% of those who belong to the first three age groups and 43.8% of women older than 50. Such information have been received from the medical staff when it comes to 22% of women aged 20 to 29, 24% of women aged 30 to 39, a quarter of women aged 40 to 49 and 43.8% of women aged 50 years and more. Among women aged 20 to 39, there is no uninformed about these issues. Within the age group of 40 to 49, 6.2% identified themselves as uninformed, as well as 3.1% of women aged 50 years and more. For women who come from urban areas, the main source of information is medical staff (53.6%), media (34.8%) and none of them are uninformed. In rural areas, 64.5% of respondents have received the information by the media, significantly less (19.4 %) by medical staff, while 6.5 % are not informed about this topic at all.

From the perspective of the educational structure of the sample, women with primary education are mostly informed by the media (46.2%), slightly fewer (38.5%) by the staff in medical institutions and 7.7% are not informed about prevention possibilities. Women with secondary education are also generally informed about prevention by the media (56.8 %) or in health care institutions (34.1%). A small percentage (4.5%) have had an opportunity to hear lectures about prevention at work or at school, while 2% are not informed at all. Women with higher education prefer to get information by the media (60.5 %), but consider medical staff being also a significant source of information (23.3%). Approximately 14% have heard lectures on this topic at work /university. There are not uninformed within this educational category.

When it comes to information by television, 74% of respondents had the opportunity to watch TV programs dedicated to the prevention of cervical and breast cancer, while 17% only during special media campaigns dedicated to these topics. A small number of respondents (7%) are not interested in watching this type of content on television, while 2% believe that national television stations lack this type of content (Figure 1).

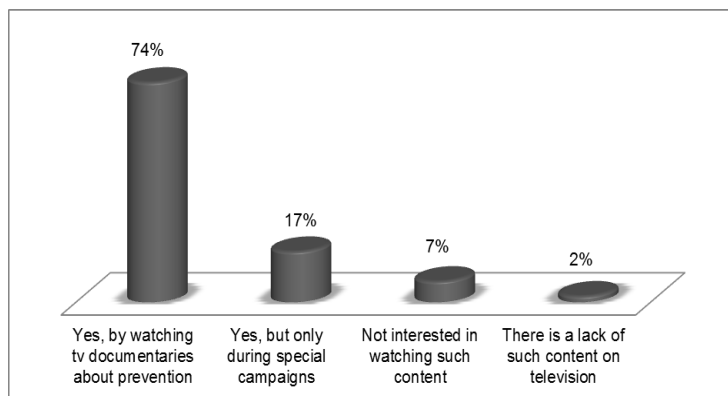

Figure 1. Informing about cancer prevention through television

Radio shows dedicated to the prevention of cervical and breast cancer has so far listened 48% of women and 20% of them only during specific campaigns. A small percentage (6%) is not interested in listening to the radio content of this type, even though they have had a chance to do it, while 26% of women believe that radio stations lack information of this type (Figure 2).

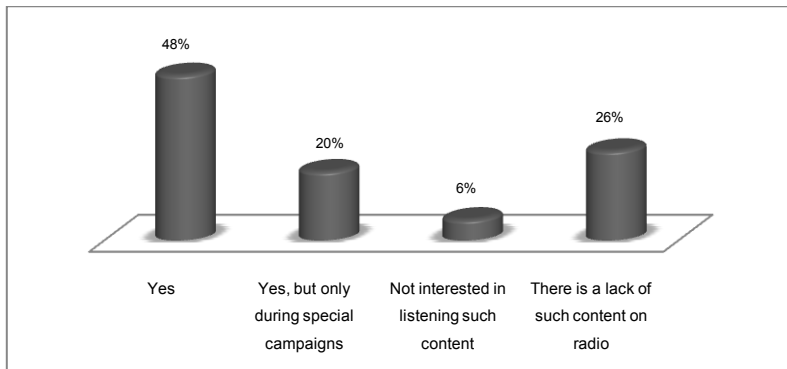

Figure 2. Informing about cancer prevention through radio

When it comes to information by printed media, 34% of respondents have had the opportunity to read the articles dedicated to prevention of breast and cervical cancer in daily newspapers and 54% in specialized magazines about health. A small number of women (8%) are not interested to read this type of articles in the press, while the lowest percentage, 4%, considers that these issues are not provided enough attention to in national newspapers and magazines (Figure 3).

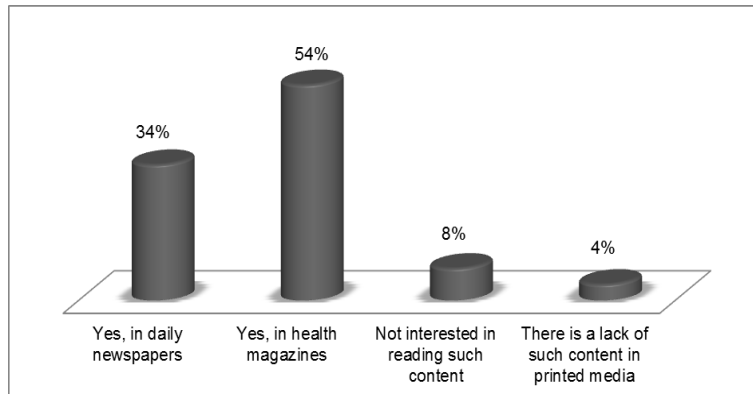

Figure 3. Informing about cancer prevention through printed media

As shown in Figure 4, 42% of women have informed themselves about preventive measures on sites dedicated to health and one fifth of them on the sites of medical institutions. Blogs or forums on health, follows 13%, mostly younger, women, while a quarter of respondents have not read about these topics on the Internet.

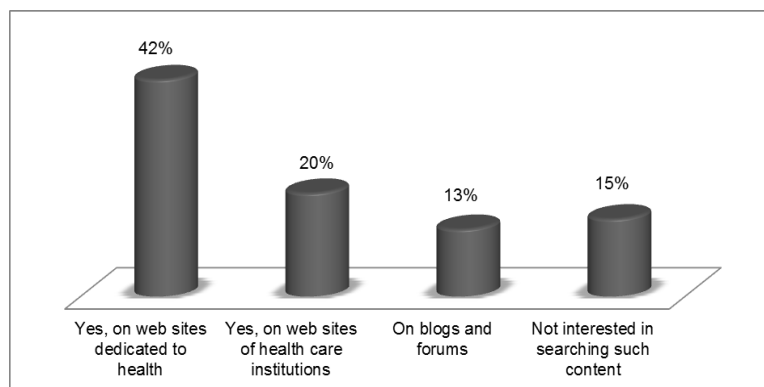

Figure 4. Informing about cancer prevention on Internet

The highest percentage of women (84%) have informed about methods of prevention through posters in health facilities or brochures that have been given to them in these institutions. Among them, 71% have read the promotional material in detail, while 13% have not been interested in reading it. Sixteen percentages of respondents had never seen or received promotional material of this type in medical institutions (Fig. 31).

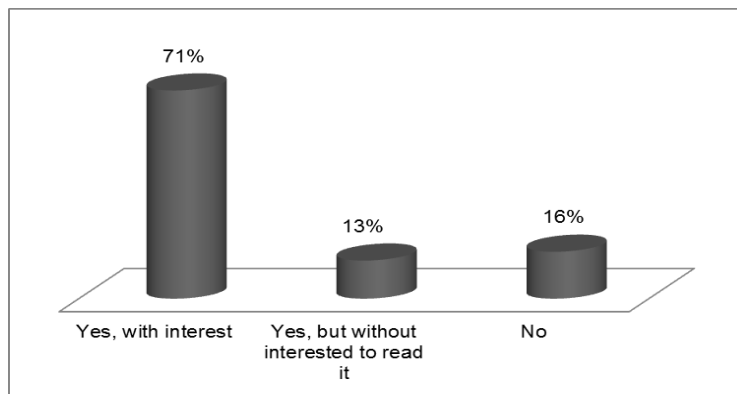

Figure 4. Informing about cancer prevention through posters and brochures

In relation to the attitude of respondents regarding the most responsible subjects for the education of women about cancer prevention, in most cases these were health institutions and the Ministry of Health. Most women who belong to the age group of 20 to 29 (38.7%) believed that the Ministry of Health played a major role, followed by the media (29.8%) and healthcare institutions (29%). Only 6.5% of younger respondents stated that every woman should educate herself on her own initiative. Women aged 30 to 39 thought that the main role belonged to health care institutions (52.4%), media (28.6%) and the Ministry of Health (19%), while the initiative is not on women themselves. Women aged 40 to 49 also stated that health care institutions played the main role in education (56.2%), then the Ministry of Health (31.2%), media and women by themselves (6.2% each). Women, who are 50 or older, as the most important, considered the role of health care institutions (43.8%), but a significant number (31.2%) highlights the importance of taking self-initiative. A quarter of women within this age category considered that the Ministry of Health had a fundamental role in encouraging the education of women in the area of cancer prevention (Figure 5).

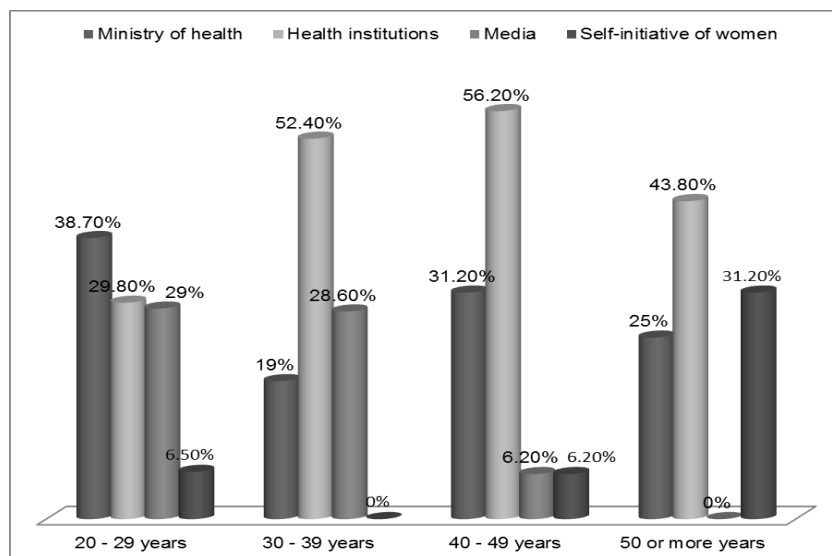

Figure 5. Role of different subjects in informing and education about cancer prevention

The largest percentage of respondents from both, urban areas (39.1%) and rural areas (51.6%) believed that health care institutions were the most responsible, followed by the Ministry of Health (30.4% in urban and 25.8% in rural areas). Respondents from urban areas also emphasized the role of the media (18.8%) and, at least, self-initiated education of women (11.6%). Women in rural areas valued more the role of women self-initiative (16.1%) than the role of the media (6.5%). From the perspective of the level of education results are as follows: women with primary education equally valued the role of the Ministry of Health and health services (38.5% each), followed by the role of the media (15.4%) and self-initiative of women (7.7%). Women with secondary education considered that institutions played the main role (59.1%), followed by self-education of women (20.5%). Around eleven percentages thought that the media played a major role, while 9.1% thought that the Ministry is more responsible. Higher educated women, at most, emphasized the responsibility of the Ministry of Health (46.5%), then health care institutions (27.9%), media (18.6%), while the lowest percentage (7%) emphasized the role of self-initiative of women.

5. CONCLUSION

Changes in medical practice in recent decades have caused the introduction of marketing communication in this sector. Social and economic trends that affect the health care sector show imply an increased need to inform and create awareness of target public in order to motivate behaviour change in the way of adoption of preventive measures. Such measures could contribute the reduction of the mortality rate of certain types of cancer, including breast and cervical cancer. Results of the research indicate that television is the leading media when it comes to information on these topics. Posters in health facilities or brochures given to women in these institutions are also considered significant. When it comes to the attitude of respondents regarding the subjects that are most responsible for the education of women, health institutions and the Serbian Ministry of Health are considered as the most important.

REFERENCES

- Bratt, J. H., Weaver, M., Foreit, J., De Vargas, T. & Janowitz, B. (2002). The impact of price changes on demand for family planning and reproductive health services in Ecuador. *Health Policy and Planning*, 17 (3), 281–7.
- Cheng, H., Kotler, P., & Lee, N. (2009). *Social Marketing for Public Health - Global Trends and Success Stories*, Jones & Bartlett Publishers, Sudbery, USA.
- Ferlay, J., Shin, H. R., Bray, F., Forman, D., Mathers, C., & Parkin, D. M. (2010). Estimates of worldwide burden of cancer, GLOBOCAN 2010 - Cancer Incidence, Mortality and Prevalence Worldwide, IARC CancerBase, Lyon, France.
- Janković, S., Gledović, Z., & Marković – Denić, Lj. (2004). Malignant tumours: Epidemiology, aetiology and prevention, Medical Faculty, University of Belgrade, Beograd, Serbia, pp.133-173.
- Kelly, M.P., Crombie, H., & Owen, L. (2004). The Contribution of Smoking, Diet, Screening and Treatment to Cancer Mortality in the Under 75s, Health Development Agency, London, UK. Retrieved from <http://www.publichealth.nice.org.uk/documents/cancerunder75sbriefing.Pdf>, 28.10.2013.
- Killoran, A., & Kelly, M.P. (2004). Towards an evidence-based approach to tackling health inequalities: the English experience, *Health Education Journal*, 63, 7–14.
- Kostic – Stankovic, M. (2013). *Marketing Communications in Customer Relationship Management*, Belgrade: Andrejevic Endowment.
- Kostic – Stankovic, M. (2011). *Integrated Business Communications*, Belgrade: Faculty of Organizational Sciences..
- Kotler, P., Shalowitz, J., & Stevens, R.J. (2008). *Strategic marketing for health care organizations: building a customer-driven health system*, 1st Ed., Jossey-Bass, San Francisco, USA.
- Labonté, R., & Laverack, G. (2008). *From local to global empowerment: health promotion in action* Palgrave Macmillan, Basingstoke, Hampshire, UK.
- Labonté, R., & Schrecker, T. (2007). Globalization and social determinants of health: The role of the global marketplace, *Globalization and Health*. Retrieved from: <http://www.globalizationandhealth.com/content/3/1/6>, 25.10.2013.
- National Commission for Health Education Credentialing, (2007). Responsibilities & competencies. Retrieved from: <http://www.nchec.org/aboutnchec/rc.htm>, 28.10.2013.
- Nicholson, P.J., (2001). Communicating health risks, *Occupational Medicine*, 49 (4), 253 – 258. Retrieved from: <http://occm.oxfordjournals.org/cgi/reprint/49/4/253.pdf>, 28.10.2013.
- Peréz, M. A., & Raffy, R. L., (2008). *Cultural competence in health education and health promotion*, Jossey-Bass, San Francisco, USA.
- Plsek, P.E., & Wilson, T. (2010). Complexity, leadership and management in healthcare organisations, *Quality United BMJ*, 32 (7315), 746–749.
- Pokhrel, S., & Sauerborn, R. (2004). Household decision-making on child health care in developing countries: The case of Nepal, *Health Policy and Planning*, 19 (4) 218–33.
- Rifkin, S. (2003). A framework linking community empowerment and health equity: It is a matter of choice, *Journal of Health and Population Nutrition*, 21 (3), p.173.
- Roman, K., Maas, J., & Nisenholtz, M. (2003). *How to advertise* (3rd Ed.), St.Martin's Press, New York, USA.
- Siegel, M., Lotenberg, L. (2007). *Marketing public health: Strategies to promote social change*. Jones and Bartlett Sudbury, USA.
- Watson, J., & Platt, S. (2002). *Researching Health Promotion*, Routledge, London, UK.

VOJVODINA AS A TOURISM DESTINATION: CITIZENS' PERSPECTIVE

Ivana Vranić¹, Slavica Cicvarić Kostić², Tamara Vlastelica Bakić³
¹ivekonomist@gmail.com

² University of Belgrade, Faculty of Organizational Sciences, cicvarics@fon.bg.ac.rs

³ University of Belgrade, Faculty of Organizational Sciences, tamarav@fon.bg.ac.rs

Abstract: *Creating a tourism destination brand is a demanding and time-consuming process. It necessarily involves local population as it plays an active role in the creation of the brand and image of the destination. This study includes an empirical research which examined the views and opinions of the citizens of Vojvodina regarding Vojvodina as a tourism destination. We have identified the main characteristics and values of the destination, which can be the basis of a successful brand positioning. Research has highlighted the main advantages that should be used to attract tourists, as well as main features that can be used for positioning this region in the minds of tourists from the perspective of local population.*

Keywords: *destination brand, brand identity, brand image, positioning, Vojvodina*

1. INTRODUCTION

The development of tourism, business and a growing number of people that allocate a part of their earnings for visiting places around the world contributed to the development of geographical locations branding. Cities, states, regions and continents are active in branding and promotional campaigns with the goal of positioning and developing desired association for the location and arousing interest to visit it. Tourism is one of the most developed service branches in almost all developed countries, as well as the industry that achieves the biggest progress in developing countries (Gabor et al., 2012). States, regions, cities, tourist organizations and agencies, affected by economic and cultural globalization, have to fight for its place in the tourist industry. One of the ways to do so is differentiation, or the creation and development of the destination brand. The importance of the state, city, or a particular region brand is not only to attract tourists, but also in creating the image and the reputation of the state (Morgan et al., 2011).

Tourists face a lot of information on various tourist destinations. In order for those destinations to become recognizable in the market and to become famous and attract tourists, one of the starting points is to build an identity, differentiate from other destinations and to build and successfully maintain their positive image. The paper by Pike (2009) presents scholars researches that emphasize the importance of the development of destination brand identities and monitoring destination brand position in time.

In Serbia, there are significant, yet still unused opportunities in tourism, which require a serious approach, knowledge, creativity and commitment to the process of building identity and image of tourism destinations. One of these options is autonomous province Vojvodina, a region of Serbia, and it is necessary to systematize the rich and diverse offer of Vojvodina and position it as a destination brand.

This paper describes the basic concepts of tourism destination brand. As literature review points out, the basis of creating and positioning a destination brand are the brand values. Therefore, the research that is presented is aimed at identifying the values and characteristics of the destination. The survey was conducted in Vojvodina, and based on the opinions and attitudes of citizens the basic features and brand values of Vojvodina as a destination have been defined, and they can be used as one of the basis for creating a branding strategy for this destination.

2. BASIS OF A TOURISM DESTINATION BRAND

In today's market environment, one of the basic conditions for successful business is building positive relationships with stakeholders. Brand creation is one of the ways to establish and maintain positive relations, because the brand is not only the name of the company/product, but the brand is a functional and emotional well-rounded story about it (Cicvarić, 2006, p. 9).

The concept of the brand was created with the idea to differentiate one manufacturer's products from the products of other manufacturers (Kotler & Keller, 2006, p. 274). Brand represents a distinctive set of elements (name, logo, symbol, design and message) that identify and differentiate: organizations, products, services, as well as people, places, and ideas, and create unique rational and emotional associations, beliefs and expectations of customers/consumers/users (Cicvarić, 2006, p. 29). The essence of the brand is to create relationships between brand and stakeholders, and it was analyzed by Chevalier and Mazzalovo (2004). Through this relationship they define the brand as a kind of contract, which is basically the relationship of trust that includes expectations of stakeholders on one hand, and promised features of the brand on the other side. Relationship and the benefits are mutual and not purely rational, but they also involve an emotional connection.

According to Kotler (1997, p. 430) product is everything that can be offered in the market to meet a certain desire or necessity, so these products can be: physical goods, services, retail stores, a person, organization, a place or an idea. In accordance with Kotler's product concept, brand concept can be linked to all categories previously mentioned.

In this context, the concept of the brand can also be applied to places or geographical locations and destinations, so the destination brand involves a name, symbol, logo, word and/or other elements that serve to identify and distinguish one destination from competing destinations. In this case, brands provide a promise of a positive traveling experience to a specific destination to potential visitors, and they are used to reinforce and strengthen the memory of a beautiful experience for those who have already been there (Kerr, 2006, p. 277).

According to Anholt (2007) branding is the process of creating, planning and communicating an identity in order to build and manage image and reputation (p. 4). Identity is the way in which the brand should be seen and understood. The basis is a visual identity, but in addition to visual representation, identity should include core values, history, culture and other specific features (Balmer, 2001). The image is public opinion about a particular brand and it is based on many factors and influences from the environment (Kapferer, 1997, p. 32). Given that image and reputation are comprised of a range of experiences, memories, expectations and other emotions that are associated with the brand, these feelings are important drivers of human behavior, so Anholt (2007) concludes that brand image is one of the key concepts relevant to the development of nations, cities and regions (p. 5).

In the process of strategic destination branding the starting point is defining the vision and mission of the destination brand. According to Chernatony (2010), the vision of a strong brand is composed of three components that are interconnected, and they are: 1. Projection of the future environment that will be realized if the brand achieves its goals; 2. The purpose of the brand, which is the reason for its existence, 3. Values that will represent the characteristics of the brand, respectively the values that will enable the brand to achieve the purpose for which it exists. The mission of the destination brand should present the reasons for starting the destination branding process, as well as the expected benefits the brand will bring to a geographical location in the future.

Park & Petrick (2006, p. 263) cited following as main reasons for destination branding: building identity and image that can attract tourists, differentiation of destination from others and positioning in order to stimulate the consumption of tourists, image management, as well as the increase of economical contribution of tourism to the destination development. Therefore, destination branding is focused on differentiating destination from the competition, especially by developing awareness and recognition among potential customers, as well as creating a positive image of the destination. By achieving this goal, it is possible to affect the attraction of tourists, attracting investors to invest in a destination, creating trade and political engagements and agreements with other destinations/countries, the organization of events on an international level and the number of other benefits that positively contribute to the development of a destination (Anholt, 2003).

The process of branding a tourist destination is quite complex and time consuming, because it is conditioned by the nature of a tourist destination, respectively its characteristics, cultural and historical heritage and natural features, a set of activities, attractions, tourist facilities and services that a destination offers. Many of these characteristics, such as the names of destinations, geographical location and natural characteristics are already defined and can not be changed in the process of branding. Therefore, the creation of a brand identity is based on them as starting elements and further includes defining other elements of identity and a campaign that will present the destination in a best possible way, bringing it closer to potential tourists and making it desirable and attractive.

Echtner and Ritchie (2003) believe that the destination image includes the perception of its characteristics (such as, for example, location, climate, accommodation facilities, hospitality of the population), as well as some of the holistic impressions (mental images or imagination) on the spot (p. 42). Therefore, it is necessary that the image is created so that it takes into account the existing resources of destinations that are specific to a given destination, while the other side must also contain personal impressions and perceptions of visitors that are a result of creating and delivering the promised brand value.

One of important conditions for success of the process of branding a tourism destination is the involvement of all relevant stakeholders in the process, in fact that all those who have an interest in the way the destination will be presented (Garcia et al., 2012). The identity of the local population should be the starting point for creating a destination brand identity. In addition to population of the location, the following groups can be identified as the stakeholders in destination branding: the representatives of local, regional and national tourism organizations, government, businesses, the arts, culture and education organizations, media and the general public.

The study of destination image is a relatively new field in the problem of positioning tourism products. So far, several studies have been made and they clearly demonstrate that destination image has an impact on consumer behavior, and in the case of a destination with a very positive and powerful appeal there is always a great chance that in the process of decision making the customer/tourist will opt for it, in comparison to competing destinations (Gallarza et al., 2002, p. 56).

3. POSITIONING A TOURISM DESTINATION

Position of the product (brand) is a complex set of perceptions, impressions and feelings that consumers have regarding a particular brand in comparison to its competitors. It includes a ratio of own brand's image to competing brands (Veljković, 2010, p. 108). Each brand is perceived differently by an individual consumer in relation to the competitor and on the basis of attributes which are important to consumers. The position of the destination on the market is the way in which the destination is seen by the potential and current visitors in terms of experience and the potential benefits it offers in comparison to competitive destinations (Reich, 1999, p. 1-2).

According to the same author, elements that assist in positioning a destination are the name, symbol and message of the tourist destination. The destinations have their own names that it is impossible or very difficult to change. It is a constant on which tourists have already developed associations. Symbol and/or logo of the tourist destination can help identify the destination and reflect its personality. Visual or graphical display which will be linked to the destination brand are considered by the author as the mandatory element of the brand. The importance and impact that a symbol/logo can have derives from the constancy of its use and recognition over time. The message of a tourist destination is an element that is often used to describe the essence of the destination brand, but is not a mandatory element for positioning.

Genov (2013) defines four principles of successful positioning of tourism destination: clarity, consistency, visibility and competitiveness (p. 165). Clarity refers to the communication with the market and emphasizing competitive advantage, where it is important to have clear and accurate communication, as well as specific, clear and precise message. Consistency as a positioning element refers to the persistence and insistence in communicating basic ideas into messages that are broadcast to consumers. Visibility is an important element of positioning because in that way the competitive advantage finds its place in the minds of consumers in the target market. Competitiveness of tourist destinations in the process of positioning must have a good and relevant basis so its competitors could not compete with it or copy it. The destination brand values that are the basic component of the brand vision represent previously mentioned basics.

The research that is presented aims at identifying the values and characteristics that the destination has which actually should be the starting point of creation and brand positioning of a destination.

4. THE CHARACTERISTICS OF VOJVODINA AS A TOURISM DESTINATION: CITIZEN PERCEPTION

In order to identify the values and characteristics of Vojvodina as a tourist destination, the authors conducted an empirical study among inhabitants of Vojvodina, on the basis of which further steps in destination branding can be determined. As it was previously identified that residents play an active role in the creation of the brand and image of the destination (Gallarza et al., 2002, p. 61), for the purposes of this study authors

examined the attitudes of people living in Vojvodina. The study was conducted in 2013, and it was based on primary data collection and employed questionnaire as a research method. On a random sample, 128 valid responses were collected, where the share of women with 75.8% was three times higher compared to the share of men at 24.2%. The age structure of the sample included respondents aged 18 to 58, where 66% of all respondents belong to the group of 21-30 years of age.

Respondents were offered responses of values and characteristics, among which it was necessary to opt for the one with the open possibility to write additional characteristics on their own if they believe that the stated values and characteristics do not reflect their views. The answers were offered on the basis of short interviews with 32 residents of Vojvodina, made prior to the making of a questionnaire, as well as on data from a research and development project "Marketing strategy of tourism in Vojvodina", which was the basis for the design of the questionnaire.

In the opinion of interviewed citizens of Vojvodina, homesteads (typical Vojvodina farms) (32%) and the natural beauty of the Pannonian plain (27%) are the responses that have been recognized by largest number of examinees as most expressed features of Vojvodina (Figure 1). The other three answers offered are approximately equally represented: rich in tradition and culture (16%), tasty, traditional food and wine (13%) and authentic towns of Vojvodina (10%) and authentic towns of Vojvodina (10%).

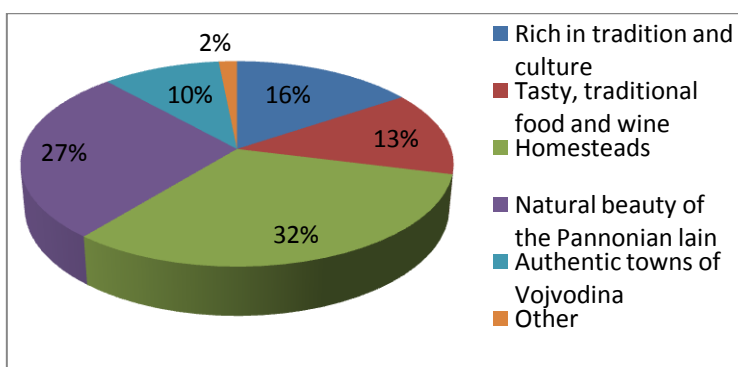

Figure 1. Most expressed features of Vojvodina

The local population was assessed by 2/3 of respondents as friendly and hospitable (Figure 2). This information is extremely important when we consider the importance that local people have in the creation of a positive brand image of the destination. When a bohemian life (13%) and preserving tradition (18%) are added to the cordiality and hospitality, it could be said that the citizens of Vojvodina are seen as a repository of friendly people.

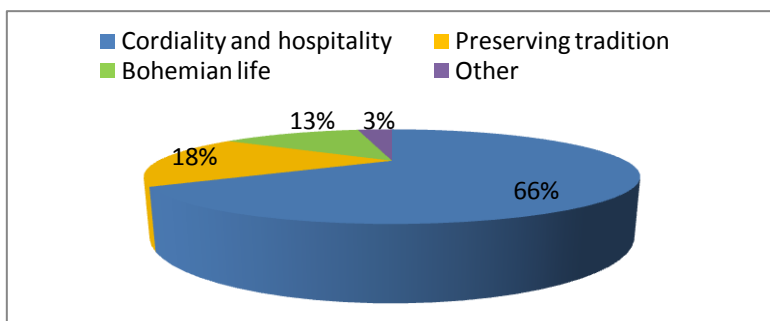

Figure 2. Features of Vojvodina inhabitants

When asked what is the main advantage of Vojvodina as a tourist area, the responses were equally represented (Figure 3). The rich cultural and historical heritage (22%), the Pannonian plain (18%), multiculturalism (19%), romantic and dreamy destinations (16%), wine and delicious traditional food (17%), and unspoiled nature with somewhat lower percentage of responses (7 %) are significant advantages in the region, while also representing a part of their resources as usable for further development, as well as to creating a destination brand.

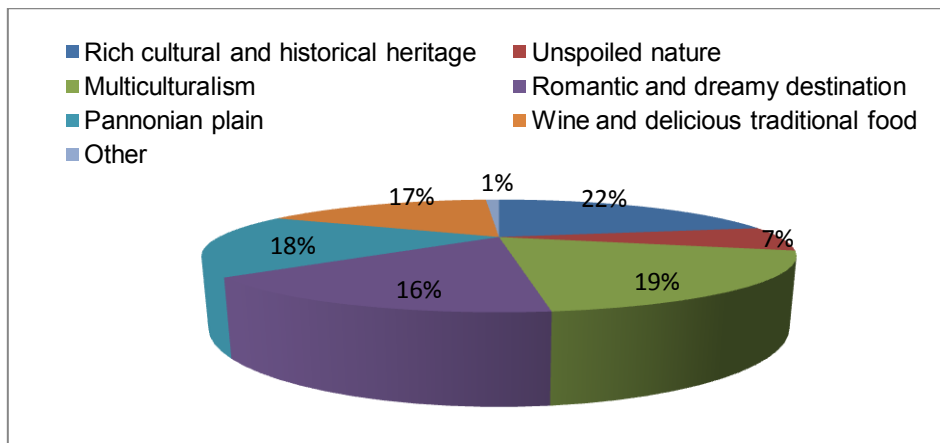

Figure 3. Main advantages of Vojvodina as a tourist region

As the result of pre-investigation, Vojvodina was described as quiet and peaceful oasis for relaxation, in the survey 88% of respondents agreed with the insignia of the region (the degree of agreement examined on a Likert five-point scale), which can be a basis for attracting tourists and creating a specific brand.

Based on the questions and answers above, the main features of Vojvodina are summarized, and they can be a starting point for building a destination brand: quiet and peaceful oasis for relaxation of mind, natural beauty of the Pannonian plain colored with fertile fields, rich culture and tradition, hospitality and kindness of Vojvodina, exceptionally delicious food and wine, homesteads and tamburitza players, as well as romantic and dreamy destinations.

Based on the survey results, by identifying core values and characteristics of the destination according to the public, Vojvodina can be positioned as a destination rich in natural beauty, as calm and quiet oasis for relaxation, with delicious food, wine and the sounds of tambourine, where with every aspect of offering there is a feeling of warmth and comfort, where the beauty and grandeur are inexhaustible.

Such positioning can include rational and emotional values, which are more expressed in this case, and it can be argued that they should lead in creating the tourism product of Vojvodina. Based on the above, Vojvodina occupies the position of a destination that promises all the benefits of rest, where every tourist can find a way and a place for enjoyment and fulfillment of expectations. In creating a destination brand strategy, it would still be necessary to explore the views and opinions of other stakeholders, and define common values on which a brand identity and further image of Vojvodina as a destination can be built.

Destination brand is a promise of an experience that potential tourists can expect from the destination. Brand positioning of Vojvodina should attract the interest and attention of potential tourists to come and visit it, stay in it and come back again.

5. CONCLUSION

Creating a successful destination brand is a complex process. Nowadays, it is no longer enough to offer basic features and attributes of a particular destination, such as geographical features, services, climate; it is necessary to create a unique and attractive offer, based on the unique characteristics and values that will attract tourists. The battle for tourists at a very competitive marketplace has become an emotional process, so the goal is to create a brand that will also affect the senses and emotions.

Destination branding is a major challenge and it requires a strategic approach in creating, positioning and maintaining brand. As one of the regions of Serbia that is rich in natural resources, culture and tradition, which respects traditional values that make its inhabitants so warm, hospitable and friendly, Vojvodina has the potential to become a preferred tourist destination. In this regard, it is necessary to precisely determine its characteristics and position it on realistic and impressive grounds, with a package of services that fully express the essence and brand promise. This paper identified the values and characteristics of Vojvodina as a tourism destination from the perspective of local population, and they can be used as one of the basis for creating a branding strategy for this destination.

REFERENCES

- Anholt S. (2003), *Brand new justice, the upside of global branding*, Butterworth – Heinemann, Oxford, Burlington
- Anholt, S. (2007), *Competitive Identity: The New Brand Management for Nations, Cities and Regions*, New York: Palgrave Macmillan
- Balmer, J.M.T. (2001). Corporate identity, corporate branding and corporate marketing - Seeing through the fog. *European Journal of Marketing*, 35(3-4), 248-291.
- Chernatony, L. (2010), *From brand vision to brand evaluation: The strategic process of growing and strengthening brands*, Elsevier, Butterworth Heinemann, Oxford, Burlington
- Chevalier, M. & Mazzalovo G. (2004). *Pro Logo – Brands as a factor of progress*, Plagrave Macmillan, New York
- Cicvarić, S. (2006), *Brend – kreiranje, pozicioniranje i održavanje*, Beograd: Zadužbina Andrejević
- Echtner, C. M. & Ritchie J. R. B. (2003), The Meaning and Measurement of Destination Image, *Journal of Tourism Studies*, 14(1), 37-48.
- Gabor, M.R., Conțiu, L.C. & Oltean, F. D. (2012), A Comparative Analysis Regarding European Tourism Competitiveness: Emerging Versus Developed Markets, *Procedia Economics and Finance*, 3, 361-366. doi.org/10.1016/S2212-5671(12)00165-7
- Gallarza, M. G., Saura, I. G. & Garcia, H. C. (2002). Destination Image – Towards a Conceptual Framework, *Annals of Tourism Research*, 29(1), 56-78. doi.org/10.1016/S0160-7383(01)00031-7
- Garcia, J.A., Gomez, M. & Molina, A. (2012). A destination-branding model: An empirical analysis based on stakeholders, *Tourism Management*, 33(3), 646-661. doi.org/10.1016/j.tourman.2011.07.006
- Genov, G. (2013), *Menadžment turističke destinacije*, Beograd: Visoka turistička škola strukovnih studija
- Kapferer, J. (1997), *Strategic Brand Management*, Great Britain: Kogan Page
- Kerr, G. (2006), From destination brand to location brand, *Journal of Brand management*, 13(4/5), 276-283. doi:10.1057/palgrave.bm.2540271
- Kotler, F. (1997). *Upravljanje marketingom - analiza, planiranje, primjena i kontrola*, MATE, Zagreb
- Kotler, P. & Keller, K. L. (2006), *Marketing menadžment*, Beograd: Data status
- Morgan, N., Pritchard, A. & Pride, R. (2011). Tourism places, brands, and reputation management, *Destination Brands*, 3-19. org/10.1016/B978-0-08-096930-5.10001-1
- Park, S. & Petrick, J.F. (2006). Destinations' Perspectives of Branding, *Annals of Tourism Research*, 33(1), 262-265. doi.org/10.1016/j.annals.2005.10.007
- Pike, S. (2009). Destination brand positions of a competitive set of near-home destinations, *Tourism Management*, 30(6), 857-866. doi.org/10.1016/j.tourman.2008.12.007
- Reich, A. Z. (1999), *Positioning of tourist destinations*, Champaign: Sagamore Publishing
- Republic of Serbia, Autonomous Province of Vojvodina, Provincial Secretariat for Economy (2009), *Marketing Strategija Turizma Vojvodine*, available at http://www.spriv.vojvodina.gov.rs/spriv_files_for_download/MSTV-revizija.pdf
- Veljković, S. (2010), *Brend menadžment u savremenim tržišnim uslovima*, Beograd: Centar za izdavačku delatnost Ekonomskog fakulteta

THE EFFECTIVENESS OF MEDIA CAMPAIGNS IN COMMUNICATION WITH CHILDREN

Anja Malinović¹, Tamara Vlastelica Bakić², Slavica Cicvarić Kostić³
¹ malinovic.anja@gmail.com

²Faculty of Organizational Sciences, vlastelica.tamara@fon.bg.ac.rs

³Faculty of Organizational Sciences, cicvaric.slavica@fon.bg.ac.rs

Abstract: *The main subject of this research were particularities of media campaigns that are designed to draw attention of children, as targeted audience, to services and products. The analysis refers to TV advertisements and examples of product ads in magazines on territory of the Republic of Serbia, which point out the main characteristics, types of message placement, and media vehicles and communication tools used in media campaign. In the research results discussion, the authors explain the managerial implications based on the research, and give directions enhancing the quality of planning and realization of media campaigns directed to children, having their better efficiency and effectiveness as a goal.*

Keywords: *marketing, media campaign, media, children, advertising*

1. INTRODUCTION

Nowadays, when the combination of modern ideas with creativity and consistency represent a prerequisite, a great deal of effort is necessary for companies and advertisers in general, to betake the market. According to Perić (2010, p. 8) the goals of media campaigns have to be conceived in accordance with the goals of customers, taking into consideration all relevant market opportunities, consumers' characteristics, their habits, as well as the primary media they are using.

Market opportunities are constantly changing, therefore, it is not sufficient anymore for a product to be in the center of attention, to be made out of the best ingredients, to be placed originally; making the field of the research itself, in the concept of modern marketing, shift towards building-up a relationship with targeted groups, indicated Filipović and Kostić-Stanković (2011, p. 94). Consequently, during a media campaign analysis targeted for children in this research, it has been noted that they are the result of combining, applying and placing special emotional aspects. The proposals, according to this study, have been organized in a way to present a planned combination in choice of media, key messages, design and presentation of ads and advertising spots.

From the communicational perspective, the goal of promotion is stimulating sales and growth of profit. Moreover, it could be redirected to creation of consciousness about the brand, encouragement of product testing, as well as placement of a product in consumers' consciousness. It can also be used for correcting wrong pictures about a product or service, as well as for reminding the consumer about the product or a special offer (Jobber and Fahy, 2006, p.237). Considering the importance and impact that media campaigns potentially have, it is important to choose adequate tactics and instruments for addressing children as targeted audience. It has been concluded in this research that it is necessary to adjust techniques and the language that is used, so that the message is clear and unambiguous, being in accordance with ethical and legal standards.

Two basic aspects of media communication are advertising and publicity. That implies the knowledge of media editing policy, the method of content production, as well as all relevant quantitative data on viewership, listenership, and readership. In order to organize a good and successful media campaign, it is also essential to understand the current media scene, its atmosphere, and the position of the primary targeted audience, and their affinities. Mainly, the goal of a media campaign is the creation of desirable media identity and organizational image, that becomes an integral part of corporate identity, and image; on long-term basis, it can be of major importance in creation and maintenance of a company's reputation (Vlastelica, 2007, p.9).

Due to a limited research and information in regards to specifications, manner of planning, and placement of media campaigns targeted to children, the authors have decided to investigate this topic and define managerial implications for improving the quality of planning of media campaigns directed to children, having their better efficiency as a goal.

2. CHILDREN AS CUSTOMERS

To understand better the behavior of children, and their contribution on the process of purchase, it is necessary to examine the determiners of their environment that influence them at a great extent. The family is the primary, relevant, and referential group that has the highest influence on an individual in consumption. The reason for that lies in the fact that the relationship between family members is much closer than in any other social group. It is only the household that is based on a set of people that form a life unit, and have socio-economic group features (Maričić, 2010, p. 219).

According to Filipović (2011) "Children are not the miniature versions of grownup people, as many companies would think when approaching them, they actually represent a very specific segment of customers. Nowadays, it has been established that children are different from grownups in the psychological profile, the manner of creating social ties, and overall perspective of the surroundings in which they are growing up. Most importantly, they possess significantly bigger amounts, and they are free to use that money independently".

One of the most common ways of defining a child is the United Nations definition, and it is read: "Thanks to the Convention, it became very simple to define a child, which is a human being under 18 years of age, unless the law of his or her country deems him or her to be an adult at an earlier age, which is rare" (Zakon o ratifikaciji konvencije Ujedinjenih Nacija o pravima deteta).

Research has shown that children, younger than 8 years of age, according to their cognitive and psychological characteristics are incapable of defending themselves from advertisers' influence. Thereby, that implies that they are not able to recognize that the goal of somebody's addressing is sales, and they accept the information that is placed through advertising to be accurate without any further pragmatic analysis. Western European countries such as Sweden and Norway forbid all advertising directed to children younger than 12 years, Greece has forbid toy advertising after 10.00 p.m., and Denmark and Belgium have made some general restrictions and bans in advertising for children (American Academy of Pediatrics, 2006).

Parents and extended family members are training children to become consumers, communicating their own experience and knowledge on products, services, shopping facilities, concept and importance of company or brand image, pointing out the price- quality relation. Social interaction in which children are familiarized with the information about a product is done through the Internet, as well as at public places (Maričić, 2010, p. 308).

Children learn how to become consumers throughout the next five following phases (Maričić, 2010, p. 309):

- observing
- demand placing
- choosing
- doing smaller (ancillary) shopping
- and independent shopping.

Beside the consumer characteristics, in this research, it has also been taken into consideration how much time children spend in consumption of media, including all ethical and legal standards that need to be consulted and respected during a production of a media campaign for children.

Act on advertising contains a range of regulations that are protecting the rights of minors during advertising (Unicef, 2011). The Act provides certain norms that do not directly apply to children, but contain norms that are of great importance in protecting minors, such as: norms on freedom of advertising, norms on verity, completeness, and singularity of a message, norms on advertising messages, norms against discrimination, and hurting moral values etc. The message must not contain elements that openly support violence or unjustified fear or addressing minors, economically and

generally dependent persons, in a dominant way. When talking about bans on influencing minor persons, according to Article 48, Act on Advertising, the use of personal property of public persons, musicians, actors, TV speakers, and others) must not be exploited in product advertising for minors. (Unicef, 2011).

Along these Acts, the following Acts are also represented that contain regulations that contribute children, as targeted group, and they are listed as Act on radio and television broadcasting, Electronic Communications Privacy Act, The Public Information Act, Law on Free Access to Information of Public Importance, Data Secrecy Law, and Personal Data Protection Act.

3. RESEARCH METHODOLOGY

The methodology that was used to identify and analyze the particularities in certain advertising campaigns was the cross case study analysis. It represents an analysis and presentation of relative cause, which is based on deduction and combination of sets of data in order to get the same conclusions (Eisenhardt, 1989). For the purpose of this research, seven TV commercial were reviewed. All spots are taken from the video-sharing website YouTube. Advertising spots are from the food product domain, and are related to products that are aimed to children in shape and manner of promotion. The products are the following: “Juhu” chocolate bars, “Barni” biscuit, Grated Plazma biscuit, “Cipiripi” cream, “Smoki smokić” flips snack, “Cokić na ekšić” beverage. The October editions from 2013 of “Bravo”, “Hey”, and “Mali zabavnik” were the subject of analysis. The analysis covered 20 newspaper-advertising pages and 8 advertorials. According to Vlastelica (Vlastelica, 2007, p. 89), advertorial is a paid text in a magazine or daily paper in a form of a newspaper article or some other editorial.

During the analysis of TV advertisements, four criteria were taken into consideration and based on them their behavior and use of certain instrument in a product presentation was monitored. Those are the following criteria: The usage of animated characters, the usage of music, the usage of family patterns, and the usage as part of social environment. Every abovementioned criteria can be seen in the Table 1, including their presence in TV advertisements.

Table 1: The criteria for analyzing television ads

	“Chipita Fineti”- sticks and dips	“Cokić na ekšić”- beverage	“Mlevena Plazma”- ground biscuit	“Barni”- biscuit	“Cipiripi”- cream	“Juhu”- chocolate bar	“Smoki smokić”- flips snack
Usage of animated characters	No	Yes	No	Yes	Yes	Yes	Yes
Usage of music	Yes	Yes	Yes	Yes	Yes	Yes	Yes
Usage of family patterns	Yes	No	Yes	yes	Yes	Yes	No
Usage of children as part of social environment	Yes	No	No	Yes	No	No	Yes

In the following graph, we can see the relation between advertorials and magazine advertising pages. Apart from that, it was also observed if the magazine contained a certain extra supplement, what is the size of the advertisement, as well as what were the advertised products and brands.

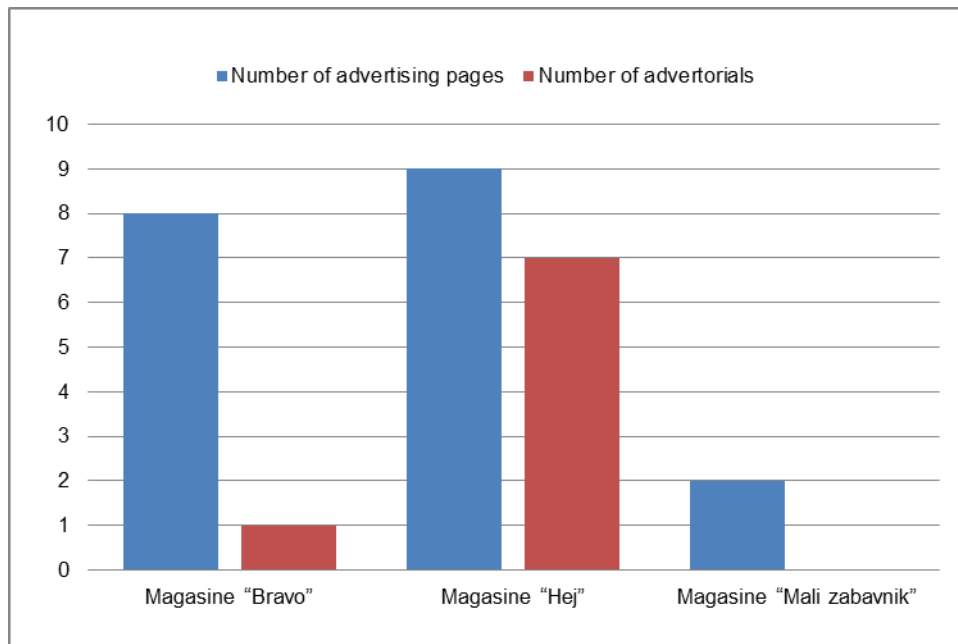

Figure 1: Relationship between number of advertising pages and advertorials

4. RESEARCH RESULTS

Using analysis and research, we can conclude that all advertisement spots last for 30 seconds in average. Looking the manner and details in choice of presentation and formulation of TV ads, and ads in children's magazines, it could be noted that the preparation was detailed and in accordance with targeted audience addressed by the advertiser or company. The ad space in the magazines was designed to make the ads notable, with adequate choice of design. The ads were usually printed on an A4 advertising space in order to present the information clearly. The ads printed on one-half of the pages were mostly brief, with too much text presenting the wrong picture of a product or service that was advertised. Every media campaign in Serbian language that went under this research had a good musical background, tune, and an adequate choice of words addressing the audience. It has been noted that if the TV advertisement is in a foreign language, the words are not pronounced properly, and the text itself is difficult to be understood

Animated characters are used in almost every TV advertisement covered in this research. If the companies decided to implement this way of advertising, they usually used an animated animal character that had some good characteristics that are related to the product that was advertised. It has also been concluded in this research that a great deal of visualized effects were used describing the ingredients of the advertised products. In addition to that, the printed editions contained photographs of a mascot in its promotional surroundings that overlaps with the promotional message that needs to be presented to targeted audience. Within the ad space in printed media, photographs of mascots and celebrity endorsers were used. These photographs remind the audience of colors of the brand, animated character, the distinctive appearance of the product. Using analysis, it has been concluded that the children are told which product they should use during their everyday activities, and if the product is to be their choice, unreal benefits of the product are represented. In advertising spots, the process of fantasizing about some certain abilities and physical manifestations after the use of a product or service is not separated clearly from the part where the product is being presented. It can also be seen that in printed media the ad spaces advertise certain services that suggest an unreal image after their use.

The use of advertorials is present in large amount in researched magazines and ads. Advertorials, in certain editions, became a basic component of magazines, such as redacted columns. Products in form of Gifts are popular, and they are pointed out in advertisements.

It has been concluded in the research that the advertisers usually use the traditional forms of the Internet activity and social media. It is shown in the next Table which of the advertisers has a

corporate website, product website, Facebook page for their product, and Twitter or Instagram account.

Table 2: Online activities of advertisers

	“Chipita Fineti”- sticks and dips	“Cokić na eksić”- beverage	“Mleveni plazma”- ground biscuit	“Barni”- biscuit	“Cipiripi”- cream	“Juhu”- chocolate bar	“Smoki smokić”- flips snack
Corporate web site	Yes	Yes	Yes	Yes	Yes	Yes	Yes
Product web page	No	No	Yes	No	No	No	Yes
Facebook page	No	No	Yes	Yes	Yes	Yes	No
Twitter	No	No	No	No	No	No	No
Instagram	No	No	No	No	No	No	No

5. DISCUSSION

Considering the fact that the advertiser and the company address a specific targeted audience, an adequate approach has to be made. In that way, all advertising spots last in average up to 30 seconds, which is short enough to keep the viewers focused, and to be efficient since it is enriched with varied contents. On the other hand, it is long enough to present the necessary segments and advantages of a product.

Certainly, an adequate research of media characteristics has to be made in order to have the realization of a campaign within the right media that will have an adequate influence on the targeted audience. Therefore, the planned budget and costs for a certain media campaign will be covered having realistic results. The size of an advertisement in printed media is also one of the factors that need to be taken into consideration. Big, simple ads, with clear photographs are clearly transmitting the advertiser’s intended message.

TV advertisement that had a good musical background, tune, and an adequate choice of words, represented the product in a more explicit and proper way. Though some information indicated that, some tunes were described as irritating among the consumers, at the same time they were the trademark of a certain product. The amount of presented characteristics of a product is less notable if presenting a simple dialogue between the actors within TV advertisements, including simple music in the background. When the children are suggested a product within a tune, that has some stylistic components such as rhymes and jokes, they will acquire the message more easily, and be informed in a way that is familiar to them. In the process of placement and organization of an advertising spot, it is recommended that the music follow the characteristics of the product and its purpose. By using a control test group, it could be determined if the tune is catchy, pleasant, and if the text is notable. The tune is of essential importance, but the text has to be adjusted. Since the children at that age are still not completely familiar with other languages, a Serbian language form of a text is suggested. Apart from that, the voice in the advertisement should be adjusted with the character pronouncing it; the language should be simple and clear.

All the media campaigns that fell under the research had a celebrity endorser or a mascot for every product. The latest products, or products that are to be placed on the market, should connect main attributes and key messages to a certain designed mascot or character if there is not an animated character or a real presentation of a mascot, the visualization of the product character is harder, including its association with a certain company. Product branding and its placement on the market are certainly eased if there is an adequate character designed for the product. The option of combining photographs, sound, and movements on the TV gives the anticipated results with an occasional appearance of the product character. It has been noted that the photograph of a mascot within printed media, evokes same associations with the same product as in TV commercials. Hence, a photograph of a character is suggested, which would enable its connection to the product, as well as to the advertiser.

Visualization and conjuring the taste throughout real pictures of ingredients are a better choice than animation of main ingredients. The analysis of spots advertising sweets, which are pointing out the appearance of ingredients of products to targeted audience, gives a better insight of a product itself. Based on the research results, a presence of a photograph within a TV advertisement is suggested along with the ad space in printed media. The analyzed media campaigns for children have not shown a notable list of ingredients, or certain components, which raise questions on everyday basis (i.e. suggested daily sugar intake). Children as targeted audience will not understand the importance of the abovementioned characteristics, but the financially solvent family members will, even within a smallest research or having the smallest interest in the product, more easily decided to buy that product.

Apart from previously provided parts of the research of advertisement campaigns, it has also been noted that special attention was paid to some special gifts that are granted with the original product. It has been noted that the ad campaign for chocolate bar "Juhu" designed a package that has free scrapbook pictures. The child sees it as a way of amusement and granting beside the basic product, enabling an extra activity for him or her. Emphasizing the importance of the present within a product in media campaign, a positive reaction is evoked. That data can be clearly presented in all types of media advertisements, and upon presenting the extras and presents, it is necessary to introduce their diversity and ways of getting a hold of them. It is also important to put the appearance and the purpose of presents into a media campaign, making the targeted audience better understand why the product is targeted to them. Innovations that could be presented at the market are the new kind of products that is offered within the packing. Therefore, apart from the usual scrapbook pictures and rubbers, those products could also be designed for males or females, in forms of hair bands, simple makeup, or key ring flashlights. In addition to that, a groundbreaking move would be making of an exclusive partnership with some of the grand chains of toy stores, or with popular heroes from certain companies where small figurines are distributed with the product. That would enable a possibility to make a new TV advertisement which could be posted as an advertisement in the newspapers, representing a new partnership.

While doing the analysis, it was noted that apart from the animated characters, the context of the ad is very often put in a realistic time, situations and children's activities. That is why the children become far more happy and capable after the use of the product. The use of certain products and services that contribute physical and psychological advance is often suggested in TV and newspaper ads. This trend of showing realistic situations should be continued in future media campaigns, but overemphasizing and delusion making in what are the effects after using a product should be avoided.

In the retrospect of the use of advertorials in printed media, that were the subject of this analysis, it can be noted that the texts are related to the use of some cosmetic products and consumption of food products. This mode of disguised advertising, that suggest the use of products, is not in accordance with ethical standards, and could jeopardize the company image, once recognized by the consumer.

In addition, an essential part of good media campaign is an active and adequate communication with the targeted audience on social media and on the Internet in general. The shortage of an official web page, as well as a well-organized corporate review of information regarding the product, creates the impression of inadequate care of the company for consumers, and a bad image that is being built. In addition, use of new social media is necessary to keep communication with target groups in pace with modern times. Certain products, that were a subject of this research, were largely criticized on blogs and forums. Given the fact that the Company feedback was missed out, the criticism continued spreading towards social networks. By following announcements and being present in online community, the Producer gained bad publicity. The advantage in following some relevant blogs is multiple, since we can get information on companies, services and products, and in that way, we can be prepared on time for potential crisis. It has also been determined that if a product possesses its own website, its information is more complete, the product seems to be more serious, and it is more accentuated on the market. Interactive websites and Facebook pages where the children are offered special activities, such as games and different creative contests are proven to be very dominant. Based on the research, if the information on a product is strictly within a domain of the corporate website, it is desirable to have a specially determined and technically presented part within the website, so that the user does not spend too much time on finding the right information.

6. CONCLUSION

Children as consumers are being noticed at a greater extent by marketing experts and media planners. Nowadays, it is not questioned if children have influence on the process of buying, but how big that influence is, and how it changes during the time. Along with the process of socialization, they also notice a great amount of products, which have been surrounding them in the everyday communication. Family, as a primary social group, builds certain consumer habits toward the youngest family members. Children under the age of eight are not aware of the nature of certain advertising messages, and are not able to protect themselves from their influence. They notice that there are products, which are placed through various media, on every-day basis.

The aim of this paper was to give an insight into media advertising towards children in Serbia, which covered a certain number of television spots and advertisements, by researching specific media campaigns for children in general. Research was done using seven television spots, and three editions of children's magazines where 20 pages of advertisement and 8 advertorials were observed and processed. Research included activities on social media, on the Internet in general. Television spots were observed using four types of criteria and those were Usage of animated characters, usage of family motives, usage of motives of children in social environment and usage of music as a factor.

The study concluded that media campaigns aimed at children generally use certain mascot or trademark personality of the product. In addition, music and tone of voice are important factors that affect the level of understanding and interest in the promotional message. TV spots last for thirty seconds, and the most common format of advertising in printed media is one full page. It was concluded that spots mainly present ingredients that are consisted in the advertised product. The analysis shows that the use of the product is associated with real situation and activities of the children, and it often suggests unrealistic benefits of consuming the product. The use of advertorials is very pronounced in certain editions of the magazine. The study also concluded that advertisers generally use traditional forms of the Internet activities and social media. In order to increase efficiency and effectiveness, in the implementation of activities targeted at the youngest audience, it is necessary to further research the topic and area of advertising and specificity of media campaigns for children.

REFERENCES

- American Academy of Pediatrics. (2006). Children, Adolescents, and Advertising. *Pediatrics*, 118(6), 2563 -2569. doi: 10.1542/peds.2006-2698.
- Maričić, B. (2010). Ponašanje potrošača. Beograd: Ekonomski fakultet
- Filipović, V., & Kostić–Stanković, M. (2012). Marketing menadžment. Beograd: FON
- Filipović, J. (2011). Deca potrošači. Retrieved from <http://edukacija.ekof.bg.ac.rs/tema-meseca.php?temald=9>
- Jobber, D., & Fahy, J. (2006). Osnovi marketinga. Beograd: Datastatus
- Eisenhardt, K. M. (1989). Building theories from case study research. *Academy of Management Review*, 14(4), 532-550. doi: 10.5465/AMR.1989.4308385.
- Perić, N. (2008). Planiranje medija i medijskih kampanja. Beograd: Čigoja štampa
- Vlastelica, T. (2007). Medijska kampanja - Publicitet i oglašavanje. Beograd: Zadužbina Andrejević
- Unicef. (2011). Analiza zakonodavstva Republike Srbije s aspekta prava deteta. Retrieved from Unicef: http://www.unicef.org/serbia/Analiza_zakonodavstva_RS_9.2.11%281%29.pdf
- Zakon o ratifikaciji konvencije ujedinjenih nacija o pravima deteta. (n.d.). Retrieved from: http://www.paragraf.rs/propisi/zakon_o_ratifikaciji_konvencije_ujedinjenih_nacija_o_pravima_deteta.html

CHALLENGES AND OPPORTUNITIES OF INTERNET MARKETING IN SERBIA AND THE WORLD

Markov Jasmina¹, Stankov Biljana² Roganović Milijana³

¹Faculty of Economics Subotica (PhD student), jasmina.markov@gmail.com

²Higher School of Professional Business Studies, bilja.l.stankov@gmail.com

³Higher School of Professional Business Studies, milijana.roganovic@gmail.com

Abstract: *Contemporary information and communication technologies and the Internet have, to a great extent, altered the conventional manners of business and market appearance. A prerequisite for a successful business in a situation characterized by extremely strong competition and the need to, along with existing and potential consumers, build long term partnerships, implies finding new manners of appearance and communication with the consumers. Combining marketing knowledge and contemporary technologies is a recipe for achieving competitive advantages, creating an image and conquering consumers. Therefore, companies pay more and more attention to the introduction of internet marketing strategy that enables interactive communication with their consumers, 24 hours a day, 7 days a week. This paper shall attempt to highlight the significance of internet marketing to the companies that want to outperform their competition, expand their business beyond national borders and to establish continuous and interactive contact with the consumers. The aim of this paper is to point out the most important factors that contribute to the increasing use of internet marketing, challenges it still faces, as well as the situation in Serbia and the world when speaking of the use of this type of marketing.*

Keywords: *internet marketing, challenges, opportunities, Serbia*

1. INTRODUCTION

"If your business is not on the internet, then your business will be out of business." Bill Gates

Modern trends in almost all business segments, extremely rapid changes in the market and consumer preferences are getting more and more difficult to track. The development of technology and increasing use of the Internet have led to the need for quicker and more flexible appearance in the market, continuous monitoring of business and effects achieved, as well as fast response to potential problems. For this reason, marketing appearance in the Internet field has taken a special place in the business of a vast number of companies, as an effective means of achieving competitive advantage, interaction with consumers and building long term relationships with them.

An increasing number of individuals and households have access to the Internet, and the number of those who get informed about products and services via this medium or exchange opinions with other consumers via social networks, forums etc. grows daily. Today, companies have two choices, not to be present in the global network and be unaware of what consumers think of them and their products, or to take advantage of all the benefits offered by the Internet as a medium, and to always be informed regarding the attitudes and opinions of consumers, changes in their preferences, activities undertaken by competition etc.

Therefore, the majority of marketing communication in contemporary business environment consists of a bidirectional communication between the company and consumers. That said, internet marketing has opened up space for practical interactive marketing action, aimed at consumers not as a group of similar individuals, but a consumer as an individual. In addition, the intrinsic characteristics of marketing concept or key principles of marketing remain the same in this case: to create value for consumers, achieve competitive or special advantage and direct and focus aims, resources and efforts of the company to achieve the highest possible degree of customer satisfaction and their loyalty. Specificity or a new qualitative factor that has primarily been introduced to the marketing context by internet marketing is interactivity – direct or immediate with consumers and potential consumers.

Modern trends point out a remarkable growth and expansion of activities based on the use of possibilities and potentials of Internet marketing throughout the world. Today, this type of marketing is highly ranked as means of communication of companies with various profiles that have on that basis already built or wish to set up their future business orientation.

2. INTERNET MARKETING – CHALLENGES AND OPPORTUNITIES

In the last 15 years, Internet has become one of the most significant media of communication of companies with consumers. Moreover, the Internet has become a business tool, instrument of socialization, excellent place for entertainment, limitless encyclopedia and database... At the same time, Internet marketing is one of the most important phenomena in marketing theory and practice, thanks to which companies have access to consumers throughout the world and appear in the global market. David Siegel says: Internet marketing is not about building a web site, but building a web business... harmonising the power of customers (Chaffey and Smith, 2013).

Within its actions, Internet marketing uses Internet space to expand traditional marketing. That said, Internet marketing has many similarities with classic (traditional) marketing. Its aims, as well as aims of traditional marketing are to build relationships with consumers, so that the companies, through offering superior products and services, as well as through continuous communication with consumers, could gain maximum yield. In accordance to the said, it must be creative, interesting and constantly subject to change. What guarantees the success of Internet marketing is, on the one hand, a good product and attractive website, and on the other hand the attention of selected target consumers. The following four pillars of Internet marketing provide the aforementioned to the companies (McAllister, 2013):

- **Relationships** - Companies want their customers to buy from you, but customers want to know that they are buying the right thing from the right company and that after they've bought it they'll continue receiving the right support. Companies can not simply tell them that they're doing the right thing (although this actual statement does help). Companies have to convince them that they interested in THEM, not just their money, and that they interested for the LONG term. The fact is, it is easier to get a group of customers with whom they developed relationships with to purchase from company again than it is to find and develop new customers. So companies must treat their customers right, as a friends, and help them to find the real answers to the problems they bring the company, and it will help their business soar.
- **Tips of the Trade** – Companies must develop their skills at advertising and internet marketing. They need to invest in a high-quality program that is developed by the true gurus - the people who: 1) know how to succeed in the internet marketing business, 2) know how to teach others how to succeed in the internet marketing business, and 3) are going to be there supporting you as you take the steps necessary succeed in internet marketing.
- **Value Marketing** - Many internet marketers make the mistake of pushing their products to the point of forgetting Pillar 1 of Internet Marketing. People want to have a relationship with companies. They want to purchase their product, but they want to know that company have their best interests at heart. And they dont want to be sold to. So, instead of pushing something at them, even if it is the best product ever created, create an attraction for them by building company's credibility. The company must show them that she is a leader in the industry by providing them with value.
- **Have a HIGH Quality Product** - In this technological day, customers are being bombarded with sales offers, and it is often difficult to decide which item is the best one. People are willing to spend money, and they are willing to pay the price for something they find valuable, but it is got to be worth the price (even if the price is giving their attention). And since the companies are attempting to develop relationships with customers, and experiences with these customers that will cause them to provide company with good word of mouth, they should make sure that their product's quality towers above its cost.

The implementation of Internet marketing campaigns increases the efficiency of the entire marketing communication, which is achieved by creating a communication strategy aimed at creating relationships and mutual values among the company and its consumers. Internet marketing can help create a business where the customer participates – through a constant dialogue, expressing interests, requesting products and services, suggesting improvements, giving feedback and where ultimately, the customers drives the business.

2.1 Opportunities and incentives of internet marketing

Growth and development of global economy, i.e. the elimination of importance of geographical borders thanks to the development of information technology, including electronic commerce, have provided incentives for the increasing use of Internet marketing by companies around the world. New information technology that involves the use of Internet as a medium has an extremely strong impact on the development of this type of marketing. First, the Internet as a communication medium contributes to the expansion of the marketing communication field, in terms of the number of people involved. Second, the Internet allows the increase of diversity of marketing communication by combining text, video and audio components. Also, the availability of a large number of contents, outreach to a wide range of consumers and the ability of interactive control of experience make the Web one of the richest media today. Third, the

Internet has significantly expanded the intensity of information regarding the market by supplying the marketers (and consumers) with detailed, real-time information about consumers and their transactions in the market (Laudon and Traver, 2009).

The Internet and Web have revolutionized the conventional business models and greatly contributed to the appearance of new ones. The use of Internet is expanding in all sectors of the economy, which allows companies to provide a personalized experience to the consumers through adapting websites to individual preferences and allowing bypassing those contents that are irrelevant to them. This is achieved by monitoring consumer movement on the Internet and combining such information with those obtained from the consumers themselves, including, among other things, payment information, interests, hobbies and the like. Personalization greatly simplifies and makes Internet surfing and finding desired contents more comfortable.

Although today a large portion of promotional campaigns still takes place through traditional marketing media such as television, newspapers, magazines etc., the Internet is playing an increasingly important role in the positioning and continuous strengthening of brands. Personalization technology may help companies to understand the needs of their consumers and direct their marketing campaigns towards precisely defined market segments, thus achieving high response rates. The Internet, as a new medium, enables the broadcasting and publishing messages in the form of bidirectional communication, where direct communication between individuals and organizations occurs thanks to interactivity, independently of space and time. Thanks to the Web, the network is practically unlimited, so there is a possibility of constant presence and establishing contacts with potential customers throughout the world. Thus, the World Wide Web has provided marketing with new tools and benefits that may increase the success of marketing efforts, so it is rightfully considered one of the most important stimulating factors of Internet marketing.

In the mid nineties of the twentieth century, in developed countries, the concept of electronic commerce based on EDI technology started its establishment. Large and costly experiments lead to a combination of electronics and communication with traditional commercial activity. E-business greatly improves Internet marketing and represents an important factor of strengthening companies' competitiveness. Thanks to e-business, the performance of business operations through electronic technology based on interactivity has been enabled. Through horizontal and vertical integration, Web sellers will develop direct e-mail marketing while ensuring consumer protection in the processes of sending and receiving e-mail. The following table shows the impact of e-business technology on internet marketing.

Table 1: Influence of e-business technology on Internet marketing (Laudon & Traver, 2009)

E – COMMERCE TECHNOLOGY DIMENSION	SIGNIFICANCE FOR INTERNET MARKETING
UBIQUITY	Expanding the impact of marketing communications at home, work, etc.; losing significance of geographical boundaries for marketing. Classic market is replaced by virtual, and temporal and geographic boundaries are removed. Consumer benefits are improved and purchase costs are reduced.
GLOBAL REACH	Providing services and marketing communications with consumers around the world. Promotional messages can reach out to a vast number of consumers, regardless of geographical location.
UNIVERSAL STANDARDS	Costs of sending messages through internet marketing, as well as receiving feedback from consumers are greatly reduced due to common, global standards on the Internet.
INTERACTIVITY	Consumers may be involved in dialogue, establishment of communication contents and structure of information, as well as customizing products and services to their own needs and requirements. In this way the provision of individual offers for each consumer is made possible.
INFORMATION DENSITY	Possibility to collect and analyze individual, very detailed information about individual customers. Data mining Internet technology allows everyday analysis of large amounts of data about consumers in order to design adequate marketing campaigns.
PERSONALIZATION/ CUSTOMIZATION	Ability to adapt products, services, and promotional and other messages to individual consumers. In this way long-term relationships with customers are established, as well as ensuring their loyalty and strengthening the ability of marketers to create a brand.

Pursuant to the data from the table, it can be concluded that intensive and continuous changes in information technology open the door to internet marketing and represent an opportunity for its affirmation and increasing use by companies. At the same time, they lead to improvement and increase in the efficiency of internet marketing, as well as to certain alterations and transformations within organizations. This primarily refers to acceptance of new technologies with new products, services and processes by the organizations, or the formation of a virtual organization that in the future shall be one of the most significant organizational forms of business.

In addition to the Web and e-commerce as new technologies, one of the important opportunities for the increase in share of internet marketing are the changes taking place among consumers. Namely, the specificity of contemporary consumers is sophistication that is manifested in the possession of more initiative in making a choice what and how to buy. Prior to the decision on purchase, consumers seek for a large number of information provided by the Internet, i.e. the World Wide Web. Consumers search through offers and information that are available to them, evaluate the offers, consult and exchange experiences with other consumers and users, and make their decision in such a way that they themselves design (create) "their own" product. In such way, companies are trying to adapt to individual customers by providing them with personalized content. Personalization and mass customization can be used in order to deliver individualized content to individuals or groups through websites or e-mails, and to remind the consumers of a product or service offered by the companies.

Personalization can be used in order to offer innovative services to the customers. Online bookseller BOL (www.bol.com) allows consumers to choose their favorite parts from different types of tourist guides, for example, historical facts from one (Rough Guides), maps from another (Lonely Planet), but also include information about nightclubs and restaurants. Such personalized book can be printed at consumer request. Also, personalized services are provided by portals such as iGoogle, Yahoo and Excite (Chaffey, 2011). They provide an opportunity to the consumers to create their own home pages in order to deliver information they are interested in, such as weather data, interesting facts in fashion, film, technology areas etc.

Thus, under the influence of new technology there is a change in relations with customers that operates on an interactive basis, in order to create a more flexible, responsive and long term relationship with target market segments. Personalization and mass customization allow manufacturers to, taking into account every customer, create products in accordance with their needs. In order for the companies to carry out mass customization in the best way possible, today they use integrated Internet, internet and extranet in order to implement various marketing activities.

2.2 Challenges and limitations of internet marketing

Although the development of new technologies, manners of communication and changes in the needs and desires of consumers opens up numerous opportunities for advancement and growing presence of internet marketing in the strategy of company market appearance, there are also many difficulties and challenges that lead to limitations in its wider use.

The most significant of these challenges is related to the use of Internet as a medium in establishing contact with consumers. Internet access is one of the limiting factors, but there are also certain consumption related barriers that may occur with consumers that have access. In fact, a large percentage of current non-users of the Internet (51%) said that they will never connect to this network (Chaffey, 2011). Most people accept innovations with a certain amount of distrust and disinterest. Identical situation is with contemporary information technology and use of the Internet as a medium in marketing communication. Internet as a brand new form of communication was initially accepted by only a narrow circle of people – innovators, primarily scientists, military personnel and university professors. Over time, more and more people started using the Internet and the benefits it provides (Stankić & Krsmanović, 2007). However, it will take many years for the Internet and Internet business to be accepted and implemented in all parts of the world.

Technical challenges of Internet marketing encompass a large number of factors, whose influence shall, due to the continuous development of new technology and finding solutions to current problems, be largely reduced and the impact of some shall be eliminated completely. This type of limitation includes the following categories (Turban, King, Lee, Liang & Turban, 2010):

- lack of security, reliability, standards and some communication protocols;
- narrowness of the field of communication;
- software development tools are still evolving and changing radically;
- it is difficult to integrate the Internet and e-commerce software with certain existing applications and databases;

- customers have a need for special Web servers, network servers and other infrastructure;
- some e-commerce software does not necessarily have to be in accordance with some hardware or may be incompatible with some operating systems and other components.

As for non-technical challenges that Internet marketing has been facing, they cover a range of factors, from legal and ethical issues related to internet marketing, through high costs and other limiting factors. The most significant non-technical challenges are:¹

- **Effects and impacts of Internet marketing are not yet fully studied and documented.**
The Internet marketing environment is a rapidly changing field and up to now only speculations concerning its success have been made. There have been successful examples but it is only now that we are entering the maturity stage and realizing its implications. A lot of organisations are waiting for the situation to stabilize before engaging in Internet marketing activities.
- **Several unresolved legal and regulatory issues exist.**
International and national laws are slowly adjusting to the changes caused by the appearance of this new kind of online activities. Issues like taxation, ownership and ethics on the net need to be addressed.
- **Privacy issues have arisen.**
Many people are willing to offer some of their personal data in order to have more personalized services. Still, with all the modern technologies and software applications on the one side, and the lack of technical expertise and awareness on the other side, the thin line of privacy may be crossed.
- **People resist to change and are not used to faceless / paperless / non-physical transactions.**
Most consumers are used to conducting "look and feel" transactions. They are used to touching and examining the product they want to buy. Also the face-to-face contact is very important in business deals and transactions since it is related to trust. But in the new environment of faceless transactions, the concept of trust has to be reconsidered.
- **People feel that there is a lot of exaggeration and are cautious.**
People feel that there is a lot of enthusiasm but there is undocumented evidence and lack of real and concrete results.
- **People are concerned about possible breakdown in human relationships.**
People feel that transactions are de-humanized and that personal, social contacts will be reduced.
- **Many business face cultural obstacles and linguistic challenges**
- **Limitations of support services**
This limitation implies financial costs and sourcing tech support in foreign languages.
- **Costs and justification**
Development costs can be extremely high, and errors due to inexperience can result in delays. In addition, it is important that system confirmation is performed with some intangible benefits that are difficult to quantify.
- **Lack of online touch and feeling**
Potential customers are unable to see and feel the product before the purchasing act, and many of them want to know exactly what they are buying.

An important limiting factor of internet marketing is the possibility of causing negative impact on the company image, especially at a time when consumers are exposed to its impact on a daily basis. Many internet marketing activities are considered intrusive and irritating and consumers perceive them as an invasion of privacy. Unwanted electronic mail (junk mail), a growing number of promotional messages, poor targeting and the like lead to negative consumer reactions and represent a limiting factor in the success of internet marketing. On the other hand, internet marketing can be quite expensive for communicators, since the costs of acquiring consumers are high.

Certainly, plenty of time shall pass until the solutions to the challenges faced by internet marketing are found, but as the understanding of new technology and experience in its use improve, there shall be an increase in the number of internet marketing users and a higher degree of its acceptance in communication with consumers. Until then, numerous legal and ethical issues, such as the issues of privacy, intellectual property protection, freedom of speech on the Internet, as well as protection of customers and sellers from fraud and deception, shall be relevant and encourage finding modern solutions.

¹ Some of the points in the above list are adapted from: Paradkar S. (2014)., eCommerce in the Customer Empowerment Era; Schneider G. (2012)., Electronic Commerce, Turban E., King D., Lee J., Liang T.P., Turban D.C. (2010). Electronic Commerce 2010, A Managerial Perspective and <http://saravanesh.files.wordpress.com/2009/06/lecture-02.pdf> (May 2014)

3. INTERNET MARKETING IN SERBIA AND THE WORLD

In order to show how rapid is the growth of Internet economy, Boston Consulting Group (BCG) published in 2012 the results of a research according to which Internet business is playing an increasingly significant role in economic growth and that it shall in 2016, as anticipated, participate with 4,2 billion dollars in the gross domestic product (GDP) of the members of the Group of 20 most developed countries of the world (G-20) (<http://wd.rs/novosti/internet-zarada-jaca-od-nemacke-ekonomije.html>). It also showed that the Internet economy shall grow at a rate of eight percent per year in developed countries, and twice as more in the developing markets. The fastest growing sector is e-commerce, and it is estimated that online market shall double its value by 2018, given that consumers are increasingly demanding access to products and services 24 hours a day, 7 days a week, and the easiest way to do so is to perform operations online.

BCG researches state that the total Internet economy in the UK shall continue to increase over the next four years at a rate of 11 percent per year, reaching a total value of 221 billion pounds by 2016. This is compared to the expected growth rate of 5,4 percent in the USA and 6,9 percent in China. Such trend forecasts are particularly good news for small and medium companies, since the research has shown that in many countries, including France, Germany and China, small and medium companies that actively operate their business in the Internet, have obtained significantly higher sales growth, in comparison to companies that are not present enough on the Internet, and that in the past three years, their revenues increased by 12,5 percent each year. All of the above indicates that Internet marketing plays a very important role in achieving success in the contemporary, highly competitive market.

This is corroborated by the fact that the global network has become the second most important medium for advertisers for the first time, and digital promotion today covers 25,6% of the advertising market in Europe. Advertising on the internet rose last year by 11,5% in Europe and 17,29% in Serbia, as stated in the results of recently published research of the Interactive Advertising Bureau (IAB). Internet advertising revenues in the United States totaled \$42.8 billion for the full year of 2013, with Q4 2013 accounting for approximately \$12.1 billion and Q3 2013 accounting for approximately \$10.6 billion. Revenues for the full year of 2013 increased 17% over 2012 (www.iab.net). The following figure shows the trend of growth in revenues from Internet advertising in the period between 1996 and 2013.

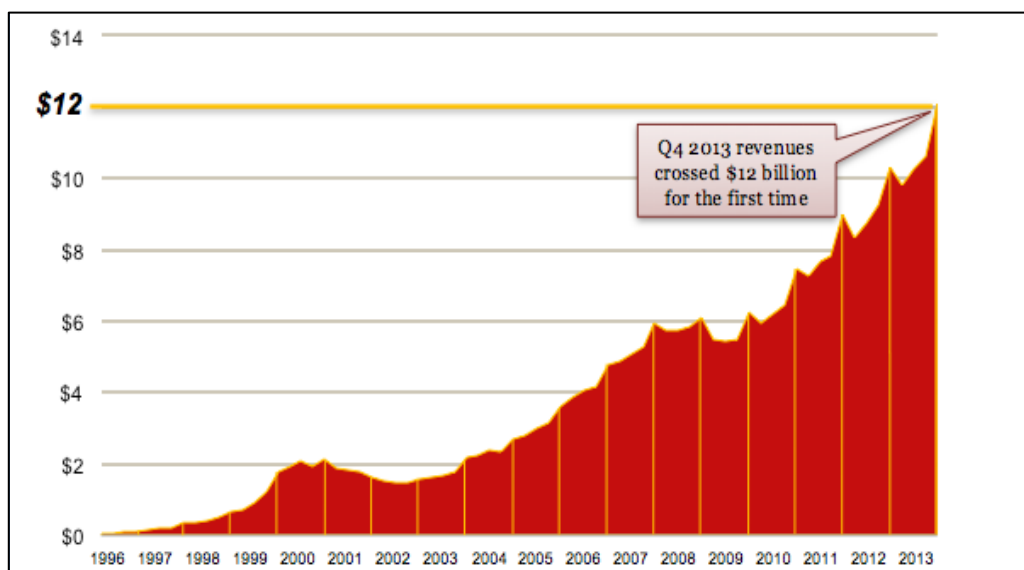

Figure 1: Revenue growth trends 1996 – 2013 (\$ billions) (www.iab.net)

This growth is attributed to the increasing number of Internet users who order products and find information on various brands in the global network. This refers to advertising on websites, social networks (Facebook etc.), and search engines (Google, Yahoo) and include promotional messages on computers and mobile phones. Only in Europe there are 426,9 million users of the global network. In America, another enormous digital market, there are more and more members of the auditorium who watch films, series and TV shows on websites. Apart from the above, advertisers have noticed that an increasing number of readers read their papers in electronic format. Analysts have estimated that Internet marketing shall, from its current share of 18 percent in marketing industry, reach a share of 23,4 percent in 2015. According to recent estimates of the European Commission, this year's rise in revenues from advertisements in online and mobile sector shall be 1,9 percent in the UK and 1,2 percent in Germany. Eastern European countries have recorded even larger growth since this market has started to develop later in these countries.

What indicates the growing importance of Internet marketing is the research how the world's top 100 companies use the Internet for marketing purposes, and the results show the following (Miljković, Alčaković & Alčaković, 2011):

- 100% of companies has a website,
- 33% have a corporate blog,
- 54% have Facebook fan pages,
- 65% have Twitter accounts.

Companies that operate in Serbia also increasingly recognize the importance of Internet marketing and the advantages it brings in reaching out to existing and potential consumers. Online advertising market is increasing along with growing habits of domestic customers to order goods and pay bills on the global network, but also to “consult” websites and forums prior to purchasing. The value of the digital advertising market in Serbia last year amounted to 14,32 million Euros, with most advertisements relating to consumer goods (18%), mobile phones (16%) and IT industry (11%) (rs.ejo-online.eu). The following table shows what techniques of appearance on the Internet and Internet marketing tools are used by companies operating in the domestic market.

Table 3: Internet marketing of top 10 companies in Serbia in 2012

Rang	Kompanije	Web site	Blog	Facebook	Twitter
1.	NIS	√	x	√	√
2.	EPS	√	x	√	x
3.	Telekom Srbija	√	x	√	√
4.	Delhaize Srbija	√	x	√	√
5.	Srbijagas	√	x	x	x
6.	Tarkett	√	x	√	√
7.	Merkator - S	√	x	√	x
8.	Delta Holding	√	x	√	√
9.	Victoria Group	√	x	√	x
10.	Koncern Farmakom M.B.	√	x	x	x

√ - exists; x – does not exist

Regardless of the presence of the majority of domestic companies in the market, their management still does not observe seriously enough their appearance on the Internet. Although 95% of the companies have their own website, they sometimes are not updated and improved for a longer period of time, or they do not follow current trends. Also, in case of holding companies, a very common situation is that every subcompany does not have its own individual website, but that the main information of all subcompanies is on the main website of the holding company. On the other hand, none of the companies have a corporate blog. Some companies have a news category where they post information which fall into the category of PR announcements rather than a blog. Given the importance of blogs in the world of Internet, it is essential for companies to change this attitude (Miljković, Alčaković & Alčaković, 2011).

The fact is that Internet marketing in our country is becoming increasingly popular, whereas budgets dedicated for online promotion from one year to another have been growing, so that in the future we may expect a large number of creative solutions in this type of marketing. Also, most analysts predict further growth of online marketing industry, since millions of people around the globe conduct business via the Internet or spend their free time on it. Therefore, the use of Internet marketing is something that companies of all sizes need to recognize as an opportunity to conquer and to better understand their consumers, as well as to construct a distinctive competitive position in the market.

4. CONCLUSION

Internet marketing is an activity that is in growth phase and gains significance daily, especially due to its great impact on the creation and maintenance of partnerships between companies and consumers. Every company that wants to be successful and recognized in the market must have a high quality Internet presentation and well-designed Internet marketing campaign. Internet marketing brings benefits to both

consumers and companies. On the one hand, consumers benefit from the availability of a large number of data and information, interactivity and immediate, continuous communication with companies 24 hours a day. On the other hand, companies have gained a powerful tool that enables flexibility in appearance in the global market, as well as the development of long term relationships with customers. Therefore, it is still unacceptable that a successful company does not have its own website, as it borders with the fact that it is almost non-existent.

Due to the growing number of Internet users in the world, online marketing is experiencing long term growth trend. Millions of people have access to the Internet from personal computers, laptops or mobile phones, which provides access to various consumers and gives a strong boost to the internet marketing industry. For those wondering what the future of internet marketing will be, it is very important to point out that the answers are diverse and numerous. Some experts say that web design will greatly affect future online success of the companies because it is a great way to attract attention and interest of the consumers. Great design is also a great way to build trust with target audience. Besides that, content marketing will be bigger than ever, considering the fact that the sole purpose of this type of marketing is presenting clear and valuable content to the consumers through variety of channels. Judging by the latest trends, the next step in advertising will be directing resources towards mobile devices which are the future. In fact, predictions say that the 87% of connected devices sales by 2017 will be tablets and smartphones. Therefore the companies must provide positive experience for the consumers that are browsing via a mobile phone through creating the alternative mobile versions of the website or by using the appropriate web design. Otherwise, it's easy to lose customers to competitors who have adapted to this trend. So called "Native Advertising", which is mentioned more and more often should provide greater efficiency of net advertising regardless of the type of format. This way of advertising implies thematic sync of the advertisement with the content consumed by the customer, i.e. even more precise targeting of the target group as well as more efficient placement of the ads. Social network advertising is becoming more and more popular due to the fact that these types of websites are appearing on a daily basis. In addition, the advertising on those types of websites is much cheaper than, e.g. banners on the most visited native websites, and at the same enables various payment models as well as much more precise selection of the target audience.

Internet marketing in our country is experiencing increasing popularity, and budgets allocated to this form of promotion grow yearly. However, despite the trend of growth of digital advertising, many domestic companies still do not realize that Internet appearance requires constant innovation and improvement, since otherwise they shall not be competitive in the future. What businesses need to take into account is to adhere to a code of conduct on the Internet, follow the examples of successful global companies and create a distinctive strategy for Internet marketing.

REFERENCES

- Chaffey D. (2011). E – Business and E – Commerce Management: Strategy, Implementation and Practice (5th ed.), Pearson: Financial Times Prentice Hall
- Chaffey D., Smith P. R. (2013). eMarketing eXcellence, Planning and Optimizing your digital marketing (4th ed.), Routledge
- Laudon , K. C., Traver C. G. (2009). E – commerce: Business, Tehnology, Society (6th ed.). Prentice Hall
- McAllister M. (2013). Discover the 4 Pillars of Internet Marketing. Retrived from www.empowernetwork.com/michellemckat/blog/discoverthe-4-pillars-of-internet-marketing
- Miljković M., Alčaković S., Alčaković S. (2011). Značaj Internet marketinga za poslovanje dvadeset vodećih srpskih kompanija, Singidunum revija 8 (2), 137 – 144
- Paradkar S. (2014)., eCommerce in the Customer Empowerment Era. Retrived from <http://www.bptrends.com/ecommerce-in-the-customer-empowerment-era/>
- Schneider G. (2012). Electronic Commerce (10th ed.), United States of America: Cengage Learning
- Stankić R., Krsmanović B. (2007). Elektronsko poslovanje, Bijeljina: Fakultet spoljne trgovine Bijeljina
- Turban E., King D., Lee J., Liang T.P., Turban D.C. (2010). Electronic Commerce 2010, A Managerial Perspective, Pearson Education
- IAB internet advertising revenue report – 2013 full year report (April 2014). Retrieved from http://www.iab.net/research/industry_data_and_landscape/adrevenue-report
- European Journalism Observatory (April 2014). Retrived from <http://rs.ejo-online.eu/category/oglasavanje-i-marketing>
- <http://wd.rs/novosti/internet-zarada-jaca-od-nemacke-ekonomije.html> (April 2014)
- <http://saravanesh.files.wordpress.com/2009/06/lecture-02.pdf> (May 2014)

THE EFFECTIVENESS OF ATL AND BTL ADVERTISING TECHNIQUES

Marijana Šehović¹, Mirjana Duduković², Jelena Mladenović³

¹Faculty of Organizational Sciences, University of Belgrade, marijana.sehovic@fon.bg.ac.rs

²Faculty of Organizational Sciences, University of Belgrade, mirchedudukovic@hotmail.com

³Faculty of Organizational Sciences, University of Belgrade, jelenamladenovic989@yahoo.com

Abstract: *The aim of this paper is to compare ATL and BTL advertising tools and to examine consumers attitudes towards these channels of communication. By analyzing several examples of global companies, we came to the conclusion that companies are increasingly turning to BTL activities and reducing their ATL budgets, allocating it for BTL campaigns. The survey we conducted showed that consumers themselves consider that BTL techniques are more efficient and effective than traditional forms of ATL communications. However, companies should not disregard the ATL activities, but they need to be creative and innovative when making campaigns.*

Keywords: *Above the line, Below the line, Through the line, Advertising, Marketing*

1. INTRODUCTION

Considering the changing requirements of today's business, many companies wonder how to best represent their products or services to customers, and therefore to encourage sales. The solution is certainly in the quality of communication with end consumers. Defining the advertising as a creative communication process, we distinguish ATL, BTL and TTL advertising techniques. Lots of companies spend large amounts of money on marketing campaigns, combining these three techniques of advertising. The aim of this paper is to examine consumer attitudes on effectiveness of these types of advertising, as well as to indicate on what kind of communication should companies be oriented.

"Marketing is the science and art of exploring, creating, and delivering value to satisfy the needs of a target market at a profit. Marketing identifies unfulfilled needs and desires" (Kotler, 2012). Marketing points out to the process of preparing the product for the marketplace. "Advertising is any paid form of non-personal presentation and promotion of ideas, goods and services through mass media such as newspapers, magazines, television or radio by an identified sponsor" (Kotler & Armstrong, 2001). Advertising is just part of the whole marketing process and it refers to making your product and service known to the marketplace. Advertising is a way of communication with customers in order to familiarize them with the product or service and therefore encourage sales.

In the context of advertising, more and more often we hear the terms "Above the line" (ATL), "Below the line" (BTL) and "Through the line" (TTL). ATL, BTL and TTL are advertising techniques. ATL is a term that indicates the promotional activities of the companies done through the mass media channels of communication. BTL is a type of advertising that encourages immediate or delayed purchase, and TTL points out to the activities that try to integrate both ATL and BTL.

2. ATL, BTL AND TTL

These terms were first used in 1954 when Procter & Gamble began paying advertising firms separately from other suppliers who dealt with more direct promotional efforts (Manral, August 22, 2011). The term originated spontaneously while composing a budget of Procter & Gamble. Only traditional advertisement costs were listed in the draft budget (television, radio, printed media, outdoor and movie theatre ads). Employees in company then considered free sampling, discount programs, sweepstakes, sponsorships, etc. which made them draw a line below initial costs, in order to include these previously uncharted costs of promotion (In the Beginning, There Was ATL, n.d.). Advertising agencies made commission from booking different types of media – TV, cinema, radio, press, magazines and out-of-home. Since BTL activities had no involvement of media, no commission was made for these agencies. The accountants marked different types of media as ATL an BTL depending on where it would sit in the balance sheet and profit and loss accounts (ATL stands for profit oriented activities, and BTL stands for non profit activities). During the time, this advertising budget structure became popular and became practiced around the world. Now, "above the line" stands for capital expenditures and "below the line" for current expenditures (Advertising, n.d.).

“Above the line” is an advertising strategy based on all types of communication, which involves the use of mass media channels such as television, cinema, radio, print, and out-of-home, in order to promote brands or present special offer (Pritchard, 2011). The objectives of ATL activities are to strengthen brand awareness, to build a brand identity and to improve the brand image about company’s product or service. This type of communication is conventional and impersonal to customers, and much more effective when the target group is very large and difficult to define. One of the major drawbacks in the ATL campaigns is the inability to evaluate the commission based on the campaign. It is impossible to calculate how much the sale increased due to campaign. For this reason, companies spend large amounts of money on ATL campaigns, without being able to measure their effectiveness. It happens that these campaigns do not give results, and companies do not have a way to deal with it. Looking at a longer time period, it is certainly necessary to communicate with consumers using ATL tools, in order to acquire the habit of consumption of the specific product. However, ATL is necessary, but uncertain.

“Below the line” uses less conventional methods than ATL, focusing on direct communication, like promotions, sampling (tastings), sweepstakes and contests, loyalty programs, “guerilla marketing”, direct mail and event marketing. BTL refers to non-media communication which is short-term incentive and mainly oriented at consumers (Pritchard, 2011). Main advantages of BTL are better targeting, direct and often personalized communication, with measurable performance (ROI can be calculated) and more tightly attached to sale than ATL. Advantage of BTL is also in communication flexibility. BTL campaigns take place at the point of sale, where consumers can make the final decision on the purchase. There is a direct interaction with customers or potential customers, indicating the opportunity for personalization of communication. Once you achieve effective personal approach, sales should increase. BTL is a common technique used for “touch and feel” products, where the customer will rather rely on immediate information about product, than previously researched items. This technique ensures recall of the brand while at the same time highlights the characteristics of the product.

ATL is facing creation awareness of the product while BTL is facing creation of a desire for purchasing the product. Above the line is much more effective tool of advertising when the target group is very large and difficult to define, while below the line is more advisable when the target group is limited and specific.

“Through the line” is related to an advertising strategy which involves both above and below the line forms, where one form of advertising indicates the target market to another form of advertising, thereby crossing the “line.” In recent years, agencies and clients have switched to integrated communication (Pritchard, 2011). Mix of ATL and BTL is used to optimize returns from these separate investments and to integrate marketer’s efforts. The main idea is to optimize the return on marketing budget spent on BTL battles than on ATL wars with well-funded competition. (PR Newswire, January 23, 2006).

3. ATL VS. BTL TRENDS AND EXPENDITURES

In the case of Canon India, this company has taken various activities (photography workshops, activities in retail touch points, consumer engagement activation, exclusive lounges, experience corners in retail shops) to engage more consumers with its products. This company’s annual marketing budget was 9,592,000.00 EUR in 2008. In 2008, the company’s marketing spend came down by 2,398,000.00 EUR, leaving it with 7,194,000.00 EUR to spend in the economic downturn, with consumers increasingly deferring their buying decisions. Technology is such a category of products where the obsolescence rate is high, so as the level of brand loyalty. Consumers decisions depend mainly on practical experience and experience of others. Company management decided to increase the BTL spend by 20 per cent, in order to provide consumers with more than “hands on product” experience. Canon India’s BTL share now stands at 70 per cent. Canon India has decided to create a better relationship with customers by sharing with them the technical knowledge on how to use the product better. The company has developed BTL strategy which included all parts of its marketing chain: consumers, traders and promoters (Tyagi, January 30, 2009).

Large corporations and well-known brands know that experience and engagement of consumers can be achieved only through BTL, so more and more marketing money is spent to connect with consumers (Balasubramanian, August 01, 2013). Estimation is that the BTL industry is growing at 25-30 per cent and will continue to grow exponentially over the next few years (Ernst & Young Report, 2012). Goal of the BTL activations is that the consumers elicit an emotional response so that they remain inspired and touched. In this way, consumers are not only introduced with the core benefits of a product, but they are honored to try or test the product, give their contribution in the form of feedback, and participate actively in the process of brand building. Thus, consumers feel special and treated with care, and the information you get in return are very valuable. Brands can’t just talk down to customers, they need to be part of a two-way communication.

Companies like Voltas, LG and Whirlpool indicate that their in-store activation budgets have been upped by as much as 20 per cent compared to last year. In many cases, BTL spendings give better return on investment than ATL. LG's inclination towards BTL has come at a rise of 15 per cent as compared to last year. Despite the high brand recall, LG feels that the process cannot be completed unless there is direct customer engagement, in-shop demonstration. Whirlpool is expecting its BTL spends to go up by 15-20 per cent than the previous year, which includes adding more hands-on in stores (Pal, May 28, 2013).

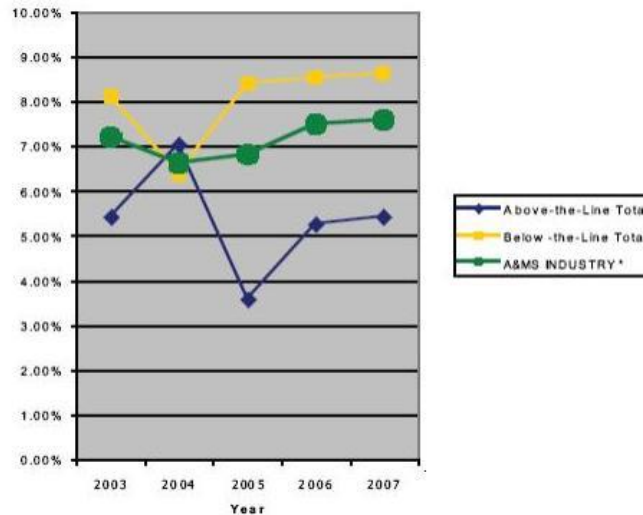

Figure 1: Growth in expenditure of BTL and ATL activities (V12 Group & Winterberry Group LLC Report, 2006)

As we can see on the Figure 1, ATL expenditures compared to BTL expenditures have decreasing trend over the years. On this figure, we can see where the efforts are, but we can not see why. It is interesting that after so many successful years with ATL methods, companies are increasingly turning to BTL approach. Also, consumers are more willing and open to BTL communication rather than ATL. There are seven trends exploring the internal and external factors that are contributing to this emerging marketing emphasis. These trends are directly impacting the allocation of marketing budgets for both ATL and BTL campaigns. Trends are given in the table below.

Table 1: Seven trends impacting the allocation of marketing budgetes for ATL and BTL campaigns (Atl and Btl Activities Research Paper, 2008).

1. Changing consumer demographics decrease the influence of traditional mass media marketing messages.
2. Growing consumer sophistication heightens the demand for channel-agnostic communications.
3. Widespread marketing “clutter” diminishes the impact of commercial messages that don’t address specific and individually relevant consumer needs.
4. Enhanced information availability empowers both marketers and consumers with insight that allows for precise customer targeting and intelligent purchase decisions.
5. Heightened client pressure to deliver quantifiable value by evaluation of ROI of the marketing initiatives , forces marketing service providers – especially agencies – to re-evaluate services platforms.
6. Growing effectiveness of “multichannel” campaigns (those that cross multiple media) reinforces demand for tactics that establish one-to-one relationships between marketers and consumers.
7. Rapid technological advances allow for consumer/marketer interactions that are more frequent, easier and more relevant than previously possible.

4. SURVEY: CONSUMER’S POINT OF VIEW

In order to examine the consumer's point of view regarding the efficiency of ATL and BTL campaigns in Serbia, we conducted an online survey, with 200 participants, where 45 % respondents are male and 55 % are female. Survey participants are Serbia citizens, where 67 % of them are currently students, 20 % are

employed and 11 % are unemployed. 26 % of respondents make buying decisions on their own, while in 61 % of respondents households, that decision is made together with other family members. In Table 2, you can see an overview of the respondents age.

Table 2: Respondents age overview

Age	Response	%
Less than 20	4	2 %
20 – 25	176	88 %
26 – 30	16	8 %
31 – 35	0	0 %
36 – 40	2	1 %
41 – 45	0	0 %
46 – 50	0	0 %
More than 50	2	1 %

Our aim was to examine the attitudes of consumers and their reactions to various types of ATL and BTL advertising techniques. The survey is designed to first examine the attitudes related to ATL, then BTL, and then to compare these techniques.

As a response to question how do the respondents react when they see a commercial break while watching television programs, 45 % said they immediately change the channel, 6 % watch commercials, while the rest devote to other activities. Many respondents do not have clear attitude about what does the TV commercials try to say and more than 50 % of them think that those commercials do not affect their opinion on products/services. Also, most of them are sure that TV ads do not encourage the purchase of goods. High percentage of the respondents consider that quality TV commercial must be short, funny, true and of course, original. Commercial that will evoke emotions, connect us with a brand and thus encourage the purchase.

Taking into consideration other ATL channels of communication, the results are given in the table below.

Table 3: Attitudes towards ATL channels of communication

Question	Disagree	Mostly disagree	Neither agree nor disagree	Mostly agree	Agree
1 Radio commercials attract attention.	36,45 %	18,69 %	20,56 %	21,50 %	2,80 %
2 Billboard advertisements affect my opinion about product/service.	17,76 %	31,78 %	35,51 %	14,95 %	0
3 Advertising in print media inform me about product/service.	19,63 %	22,43 %	38,32 %	16,82 %	2,80 %
4 I always read the leaflet I get.	23,36 %	24,30 %	18,69 %	24,30 %	9,35 %

When ranking the advertising type that most influences consumers opinion on product/service of all ATL communication channels, first of all are TV commercials. Billboard advertisements take second place, while radio and print media took an equal number of votes for third place.

When we look at the consumer's point of view of ATL campaigns, generally it seems that they are not too enthusiastic and thrilled, on contrary, they are tired and they feel this kind of marketing does not affect their awareness about product or service. Therefore, companies need to be more innovative and creative in their ATL campaigns, which is very difficult to do in a saturated market.

Talking about BTL campaigns, 42 % survey participants like to be informed about promotions in sales objects where they usually do shopping, but more than 50 % participants are not willing to inquire about the promotion by themselves. They are not ready to make first step and approach to the promo stand. Companies therefore have promo teams who have to be very communicative and pleasant, but not intrusive, who will provide necessary information at the right place, at the right time. Around 68 % of participants like to get free samples of some products at the point of sale. It is important for consumers to be able to feel, touch and taste a product which is being offered. On the other hand, less than 50 % of respondents do not like to

taste free food at the point of sale. Depending on the purpose of a product, companies need to consider whether to do free sampling or to allow testing the product at the scene.

Beside the promotion, some other BTL activities like sweepstakes and direct mails are interesting for consideration. The same percentage of respondents is interested, disinterested and neutral towards taking part in the sweepstakes at the point of sale. One of the consumers favourite BTL activation is receiving gifts when buying a certain product. Most of them declared that branded shelves in sales objects attract their attention, but great majority of them ignore informational e-mail about new products or services.

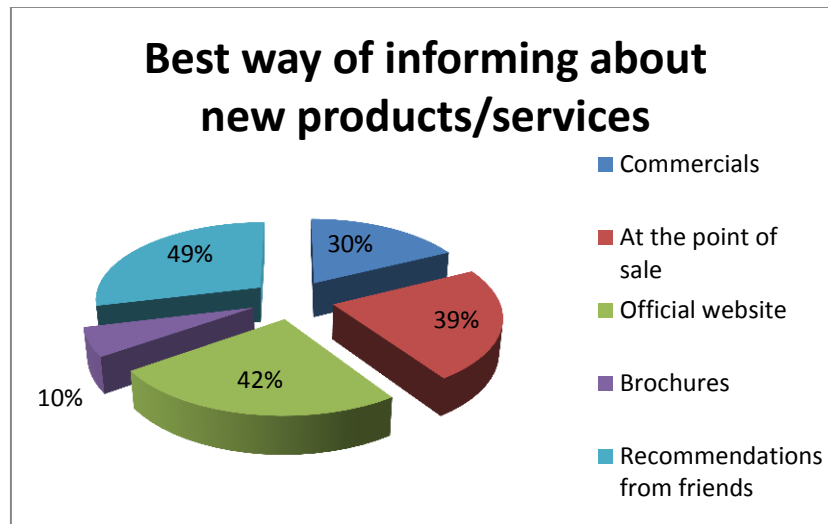

Figure 2: Best way of informing about new products/services

As we can see in the Figure 2, most of the survey participants trust a friend's recommendation when informing about new products or services. Brochures and commercials are becoming more and more the past, while websites and points of sale are becoming the future. Companies need to spend less on print materials, and to invest more in quality staff who will be qualified and capable of explaining to potential buyer everything he wants to know about certain product/service.

As a result of the survey, we found that consumers in Serbia prefer BTL communication. They are much more ready and willing to engage in BTL mechanisms than to be left to television and other ATL media. Personal, 1-1 communication makes them feel special, which contributes to the effectiveness of BTL campaigns. In this way, consumers feel like someone cares about their needs and they are creating desire for buying that product they will be thrilled about.

5. CONCLUSION

Analysing the practice of few global companies, so as results of conducted survey, we have concluded that BTL campaigns are gaining more and more importance. Marketing activities which are left to the consumer's free will, meaning that he has a choice to see them or not, are doomed to failure. Customers have less time for shopping, their taste is more refined, their money is requiring maximum quality and their wishes are more and more specific. Because of that, companies need to maximize efficiency of communicating with target customers. The effectiveness of BTL activities is rising, that is why companies are ready to invest more in BTL than ATL mechanisms. They should invest more in BTL activations and on 1-1 communication. ATL should not be disregarded, but people are getting bored with classical way of advertising. Less budget should be spent on ATL, but ATL sector must increase innovation and creativity when inventing a campaign.

REFERENCES

- Advertising*. (n.d.). Retrieved from <http://www.creativeimages.co.za/cindy/services/advertising/>
- Atl and Btl Activities Research Paper*, (2008). Retrieved from <http://www.slideshare.net/sonam2008/atl-and-btl-activities-research-paper>
- Balasubramanian, D. (August 01, 2013). *BTL spend is a critical, non-negotiable part of marketing budgets*. Retrieved from http://www.exchange4media.mobi/story.aspx?news_id=52171#sthash.NFG7xCNc.dpuf

- Ernst & Young Report (2012). *The business of experiences: The Indian events and activation industry*, India: EEMA
- In the Beginning, There Was ATL*. (n.d.). Retrieved from <http://www.marketmedia.lv/eng/instoretv/atlbtl/>
- Kotler, P. (2012). *FAQS Marketing: Answers and Advice by the Guru of Marketing*, Singapore: Marshall Cavendish Business
- Kotler, P., & Armstrong, G. (2001). *Principles of Marketing*, Prentice Hall (9th ed.)
- Manral, K. (August 22, 2011). *Difference between 'above the line' and 'below the line' advertising*, retrieved from: http://theadvertisingclub.net/index.php?option=com_content&view=article&id=3256:difference-between-above-the-line-and-below-the-line-advertising&Itemid=175
- Pal, N. (May 28, 2013). *Consumer durables up their BTL budget to 20%*. Retrieved from <http://pitchonnet.com/blog/2013/05/28/consumer-durables-up-their-btl-budget-to-20/>
- PR Newswire. (January 23, 2006). *Winterberry Group Report Quantifies Fundamental Marketing Shift as Spending Moves 'Below-the-Line'*. Retrieved from: <http://www.ulitzer.com/node/173752>
- Pritchard B. (2011). *Kick-Ass Business & Marketing Secrets: How to Blitz Your Competition*, Hoboken, New Jersey: John Wiley & Sons, Inc.
- Tyagi, Ch. (January 30, 2009). *Canon India spends 70 per cent of marketing budget on BTL*. Retrieved from http://www.afags.com/news/story/24363_Canon-India-spends-70-per-cent-of-marketing-budget-on-BTL
- V12 Group & Winterberry Group LLC Report, (2006). *Tracking the Trends: A Comparison of Above-the-Line & Below-the-Line Expenditure Trends*. New York: Winterberry Group